

**DE**

M03-03/04\_M04-03/04

**Montageanleitung**

**GB**

M03-03/04\_M04-03/04

**Mounting instructions**

**F**

M03-03/04\_M04-03/04

**Instructions de montage**

**I**

M03-03/04\_M04-03/04

**Istruzioni di montaggio**

**ES**

M03-03/04\_M04-03/04

**Instrucciones de montaje**

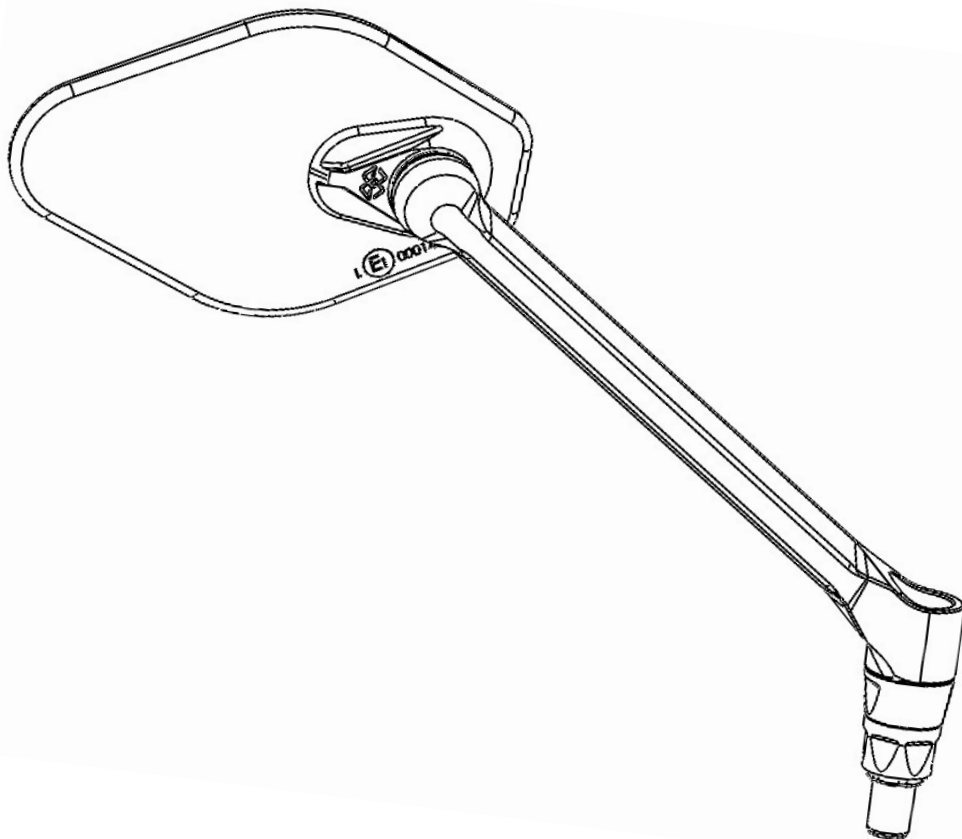

**DE**

## Warnhinweise

### **⚠ GEFAHR**

Weist auf eine Gefährdung mit hohem Risikograd hin, die bei Nichtbeachtung zum Tod oder einer schweren Verletzung führt.

### **🛠 ACHTUNG**

Besondere Hinweise und Vorsichtsmaßnahmen. Die Nichtbeachtung kann zu einer Beschädigung am Fahrzeug oder Bauteilen führen.

### **📖 HINWEIS**

Besondere Hinweise zur vereinfachten Handhabung und Montage.

## Allgemeine Hinweise

- Es wird empfohlen den Artikel von einer Werkstatt mit entsprechend geschultem Personal installieren zu lassen!
- Diese Anbauanleitung ist sorgfältig vor Beginn der Montagearbeiten durchzulesen und der Lieferumfang ist auf Vollständigkeit zu überprüfen.
- Nichtbeachtung der Anweisung kann zu Beschädigungen des Fahrzeuges, des Produktes bzw. zur Gefährdung des Fahrers führen.
- Für Schäden, die aufgrund von Nichtbeachtung unserer Anweisungen entstanden sind, können wir keine Haftung oder Gewährleistung übernehmen.
- Ein unsicher aufgestelltes Motorrad kann bei den folgenden Arbeiten umfallen! Achten Sie darauf, dass das Fahrzeug sicher steht.
- Verbrennungsgefahr bei heissem Motor und Auspuff! Heiße Fahrzeugteile abkühlen lassen.
- Die Montage und Funktion bezieht sich ausschließlich auf Serienmotorräder.
- Bewahren Sie die Anbauanleitung sorgfältig auf und geben Sie dieses Produkt nur mit Anbauanleitung weiter.

## Montagehinweise

- Alle nicht benannten Drehmomente gemäß Herstellerangaben oder falls nicht vorhanden nach DIN/ISO festziehen.
- Arbeiten und Entlüftung am Bremssystem sind von einer Werkstatt mit entsprechend geschultem Personal durchzuführen.
- Achten Sie auf Freigängigkeit bei Zügen, Kabeln und Leitungen, um Spannungen und Quetschen zu vermeiden.
- In regelmäßigen Abständen sind alle Schraubverbindungen auf ihren festen Sitz zu überprüfen.

**GB**

## Warning instructions

### **⚠ DANGER**

Relates to a hazard with high degree of risk. If not complied with, may lead to death or serious injury.

### **🛠 ATTENTION**

Special instructions and precautions. Non-compliance may result in damage to the vehicle or components.

### **📖 NOTE**

Special instructions for simplified handling and assembly.

## General notes

- It is recommended that the article is installed by a workshop with adequately trained staff.
- Read through these instructions carefully before starting assembly and check that the delivery is complete.
- Non-compliance with the instructions may result in damage to the vehicle or to the product and/or endanger the driver.
- We cannot accept liability or offer any guarantee for damage arising from non-compliance with our instructions.
- An insecurely positioned motorcycle may tip over during the following work! Make that the vehicle is safely supported when standing.
- Danger of burns in the case of hot engine and exhaust! Allow hot vehicle parts to cool.
- Assembly and function relate exclusively to standard production motorcycles.
- Keep these instructions safe and ensure that they are included with any transfer of the product.

## Assembly instructions

- All unspecified torque settings should be tightened according to manufacturer's instructions or, if not present, in accordance with DIN/ISO.
- Work on and bleeding of the brake system must be carried out by a workshop with adequately trained staff.
- Ensure the freedom of movement of bowden cables, cables and wires in order to avoid tension and crimping.
- All bolted connections should be checked for secure seating at regular intervals.

**F****Avvertissements****⚠ DANGER**

Indique un danger à haut degré de risque qui, s'il n'est pas pris en compte, est susceptible d'entraîner des blessures graves, voire la mort.

**⚠ ATTENTION**

Indications spécifiques et mesures de précaution. Leur non-respect est susceptible d'occasionner des dommages au véhicule ou à ses composants.

**📌 NOTE**

Indications spécifiques visant à simplifier le maniement et le montage.

**Indications d'ordre général**

- Il est recommandé de faire installer l'article par un atelier spécialisé.
- Ces instructions de montage doivent être lues attentivement avant de commencer les travaux de montage et le contenu de la livraison doit être vérifié pour s'assurer qu'il est bien complet.
- Le non-respect de ces instructions est susceptible d'occasionner des dommages au véhicule ou au produit, ou bien de mettre en danger le conducteur.
- Nous déclinons toute responsabilité et ne prenons en charge aucune garantie pour tous les dommages, qui seraient causés par le non-respect de nos instructions.
- Une moto mal mise en place est susceptible de tomber lors des travaux effectués dessus par la suite ! S'assurer que le véhicule est bien stable.
- Risque de brûlures lorsque le moteur et le tuyau d'échappement sont chauds ! Laisser refroidir les pièces chaudes du véhicule.
- Le montage et le fonctionnement ne concernent que les motos de série.
- Conserver soigneusement les instructions de montage et ne remettre ce produit qu'avec ses instructions de montage.

**Indications relatives au montage**

- Lorsqu'un couple de serrage n'est pas précisé, effectuer le serrage suivant les indications fournies par le fabricant, ou bien, s'il n'y en a pas, suivant les spécifications de la norme DIN/ISO.
- La purge du système de freinage et tous les autres travaux relatifs au freinage doivent être effectués par un atelier spécialisé.
- S'assurer que les câbles, fils et conduites sont bien libres de bouger afin d'éviter tout écrasement ou tension.
- Tous les fixations à vis doivent être vérifiés à intervalles réguliers pour s'assurer qu'ils sont bien serrés.

**I****Avvertenze****⚠ PERICOLO**

Segnala una condizione di pericolo con un elevato grado di rischio che, in caso di inosservanza, può portare al decesso oppure a una lesione grave.

**⚠ ATTENZIONE**

Indicazioni speciali e precauzioni. L'inosservanza può comportare un danneggiamento al veicolo oppure ai componenti.

**📌 NOTA**

Indicazioni speciali per semplificare la movimentazione e il montaggio.

**Indicazioni generali**

- Si consiglia di far installare l'articolo da un'officina specializzata.
- Queste istruzioni di montaggio devono essere lette attentamente prima di dare inizio ai lavori di montaggio e l'ambito di fornitura deve essere verificato in termini di completezza.
- L'inosservanza delle istruzioni può comportare un danneggiamento al veicolo, al prodotto oppure la messa in pericolo del conducente.
- Noi non possiamo assumerci alcuna responsabilità né possiamo fornire alcuna garanzia per i danni insorti in seguito all'inosservanza delle nostre istruzioni.
- Una motocicletta, tenuta eretta in modo precario, può cadere a terra durante lo svolgimento dei seguenti lavori! Prestare attenzione affinché il veicolo poggi stabilmente.
- Pericolo di ustione in presenza di motore e scarichi bollenti! Far raffreddare le parti calde dei veicoli.
- Il montaggio e il funzionamento si riferisce esclusivamente alle motociclette di serie.
- Conservare le istruzioni di montaggio accuratamente e, in caso di cessione, questo prodotto deve essere sempre accompagnato dalle istruzioni di montaggio.

**Indicazioni di montaggio**

- Stringere tutti i momenti torcenti, non citati, secondo le indicazioni del produttore oppure, se assenti, secondo DIN/ISO.
- Far eseguire i lavori e la disaerazione sul sistema di frenatura da un'officina specializzata.
- Prestare attenzione alla libertà di movimento in presenza di tiranti Bowden, cavi e linee per evitare tensionamenti e schiacciamenti.
- Ad intervalli regolari assicurarsi che tutti i collegamenti a vite siano saldamente fissati nella loro sede.

**ES**

## Indicaciones de advertencia

### **⚠ PELIGRO**

Hace referencia a un peligro con un elevado riesgo que, en caso de inobservancia, puede provocar la muerte o lesiones graves.

### **🛠 ATENCION**

Indicaciones especiales y medidas de prevención. Su inobservancia puede provocar daños en el vehículo o en componentes.

### **📌 NOTA**

Indicaciones especiales para una manejo y un montaje sencillos.

## Indicaciones generales

- Se recomienda encargar la instalación del artículo a un taller especializado.
- Antes de iniciar los trabajos de montaje es necesario leer atentamente estas instrucciones de montaje y verificar que el volumen de suministro está completo.
- Si no se observan las instrucciones se pueden provocar daños en el vehículo, el producto, o se puede poner en riesgo al conductor.
- Por los daños provocados por inobservancia de nuestras instrucciones no asumimos ninguna responsabilidad ni garantía.
- ¡Una motocicleta estacionada de forma insegura puede caerse al realizar los siguientes trabajos! Preste atención a que el vehículo se mantenga de pie con seguridad.
- ¡Peligro de quemaduras con el motor y el sistema de escape calientes! Dejar que se enfrien las piezas del vehículo que estén calientes.
- El montaje y el funcionamiento hacen referencia solamente a motocicletas de serie.
- Conserve las instrucciones de montaje en un lugar seguro y entregue este producto a terceros solamente con dichas instrucciones.

## Indicaciones para el montaje

- Todos los pares no mencionados se deben apretar según las indicaciones del fabricante o, en su defecto, según las normas DIN/ISO.
- Los trabajos en el sistema de frenado y el purgado de aire deben ser realizados por un taller especializado.
- Preste atención a que los cables Bowden, cables y conductos se muevan con libertad para evitar tensiones y aplastamientos.
- Se debe comprobar con regularidad que las uniones atornilladas están firmes.



M03-03-L

**1 x MB-04 (M10)**

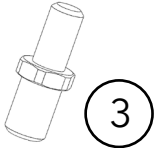

**1 x MB-05 (M10x1,25)**

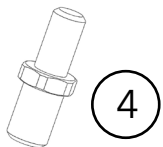

**1 x MB-06 (M10x1,25 LH)**

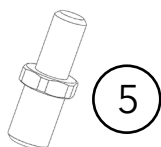

**1 x M01-UM-01**

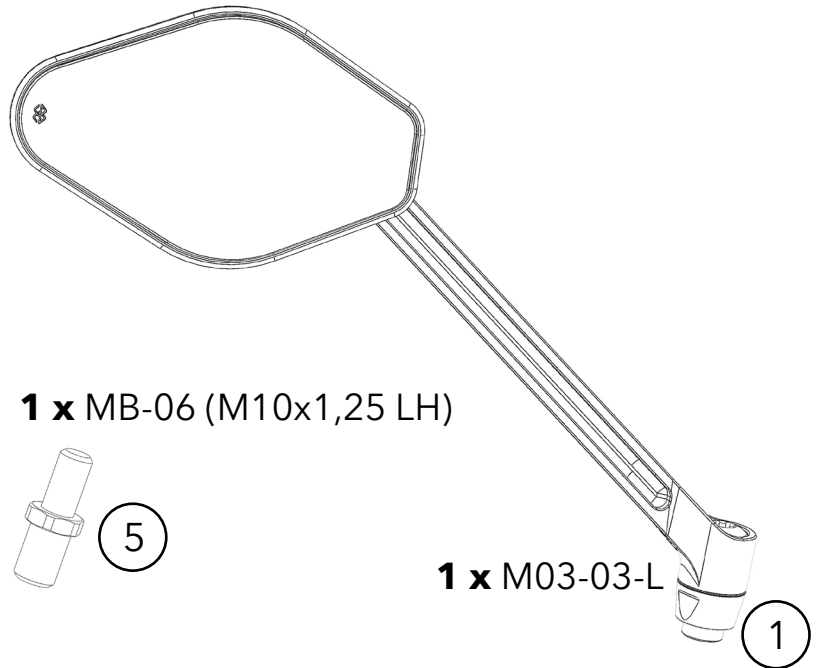

**1 x M03-03-L**



M03-03-R

**1 x MB-04 (M10)**



**1 x MB-05 (M10x1,25)**

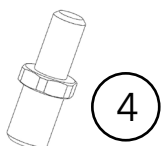

**1 x MB-06 (M10x1,25 LH)**

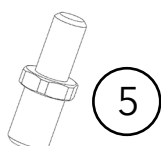

**1 x M01-UM-01**

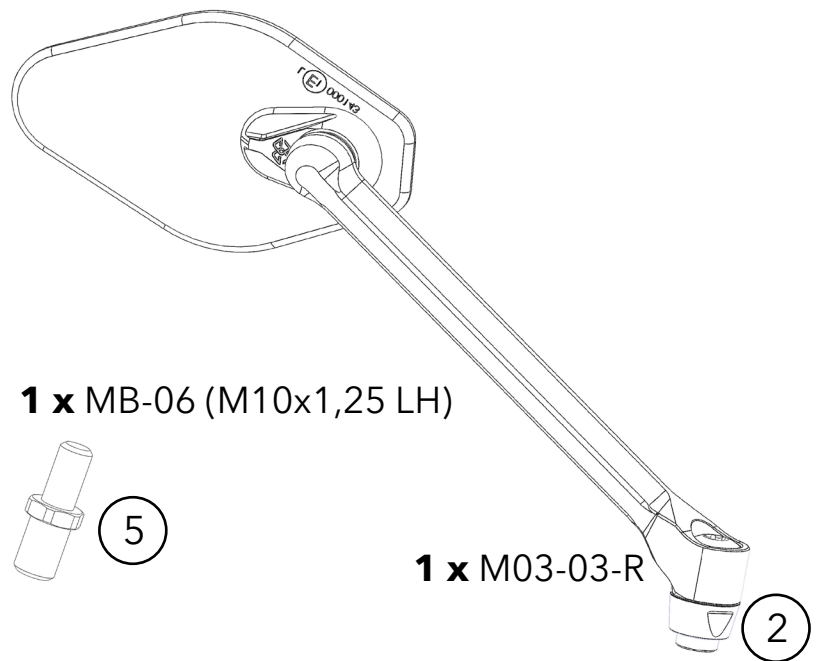

**1 x M03-03-R**



M03-04-L

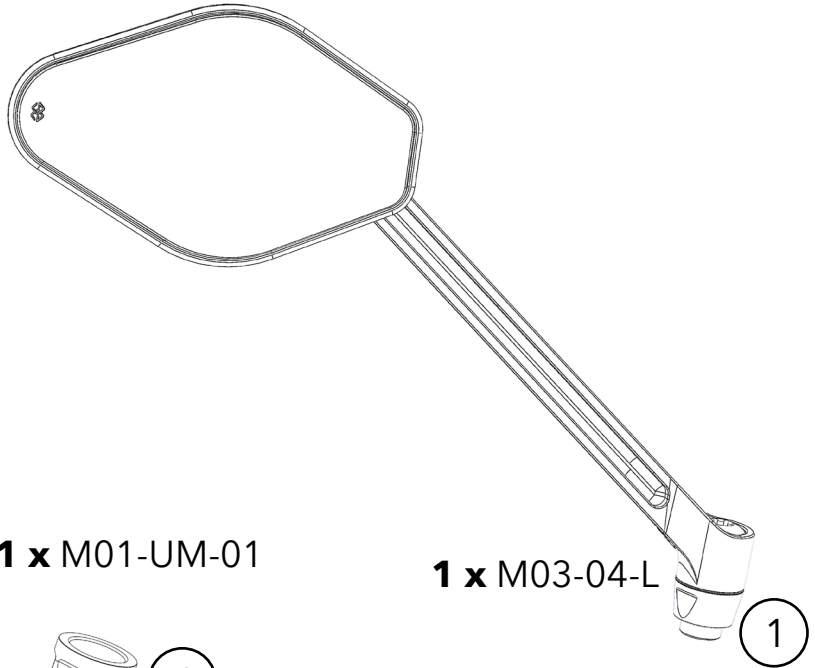

**1 x** MB-07 (M8)

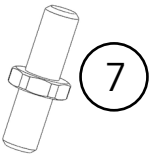

**1 x** MB-08 (M8 LH)

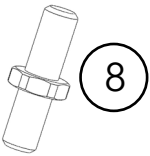

**1 x** M01-UM-01



**1 x** M03-04-L



M03-04-R

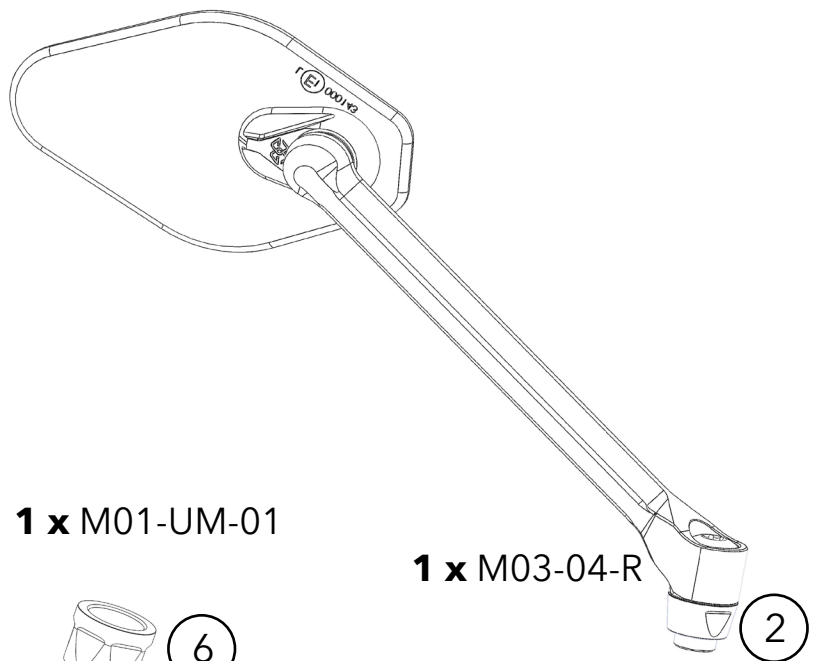

**1 x** MB-07 (M8)

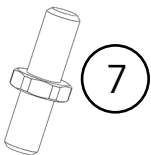

**1 x** MB-08 (M8 LH)

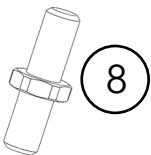

**1 x** M01-UM-01



**1 x** M03-04-R





M04-03-L

**1 x MB-04 (M10)**

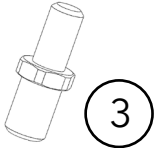

**1 x MB-05 (M10x1,25)**

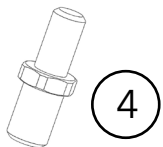

**1 x MB-06 (M10x1,25 LH)**

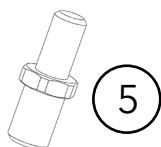

**1 x M01-UM-01**

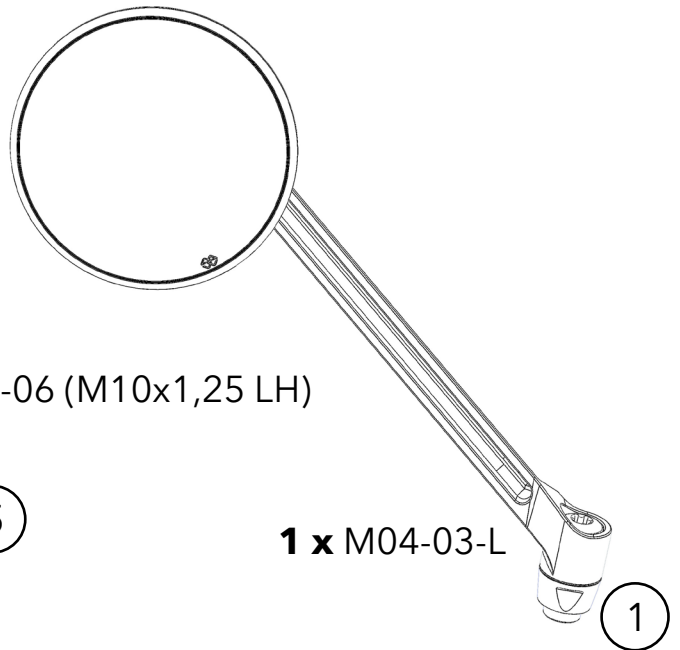

**1 x M04-03-L**



M04-03-R

**1 x MB-04 (M10)**

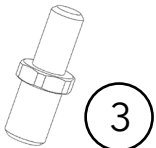

**1 x MB-05 (M10x1,25)**

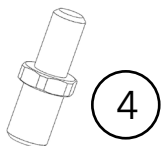

**1 x MB-06 (M10x1,25 LH)**

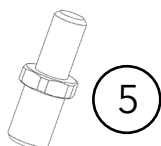

**1 x M01-UM-01**

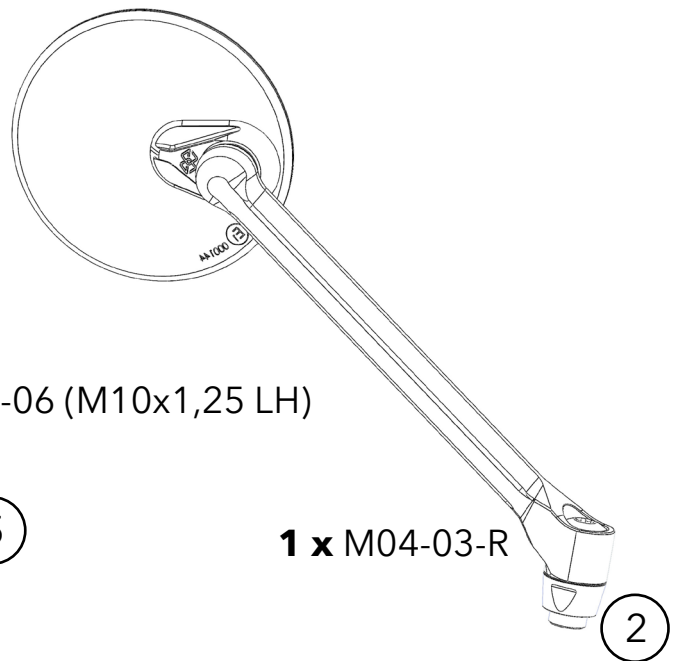

**1 x M04-03-R**



M04-04-L

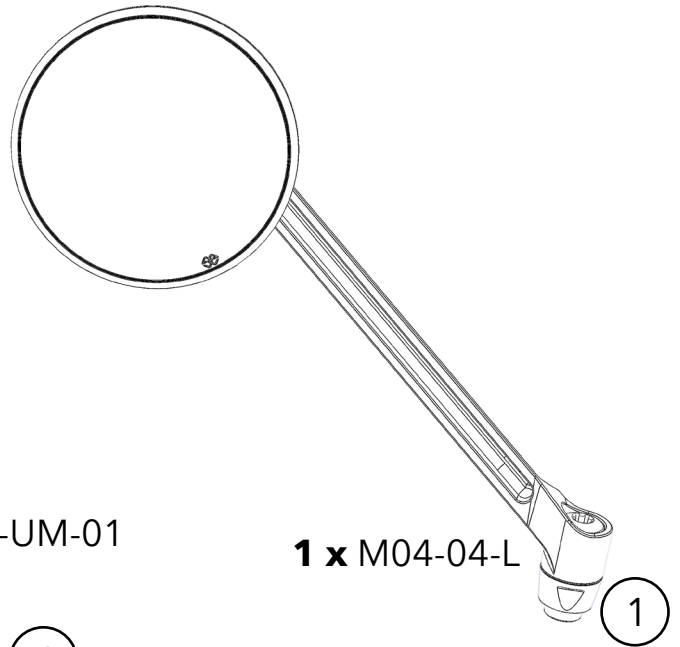

**1 x** MB-07 (M8)

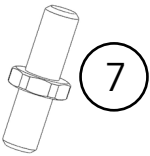

**1 x** MB-08 (M8 LH)

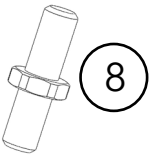

**1 x** M01-UM-01



**1 x** M04-04-L



M04-04-R

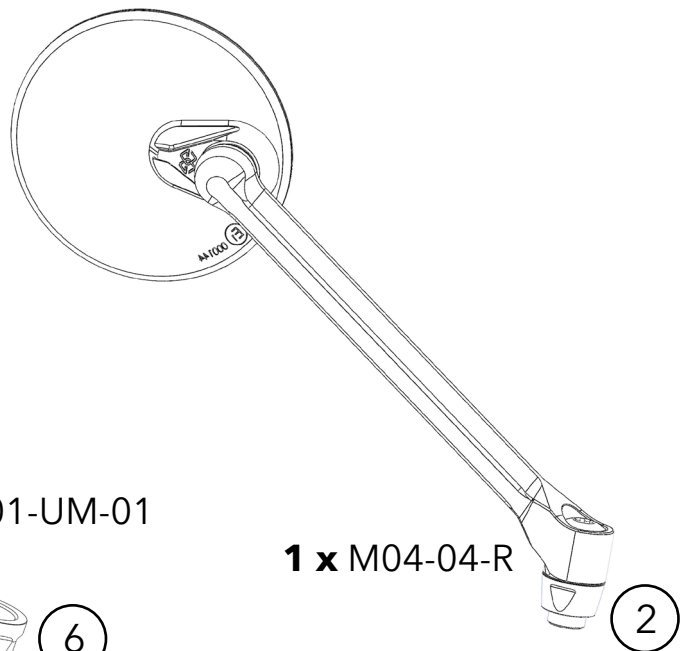

**1 x** MB-07 (M8)

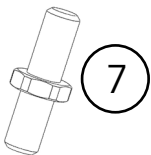

**1 x** MB-08 (M8 LH)

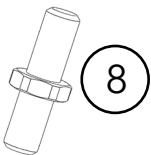

**1 x** M01-UM-01



**1 x** M04-04-R





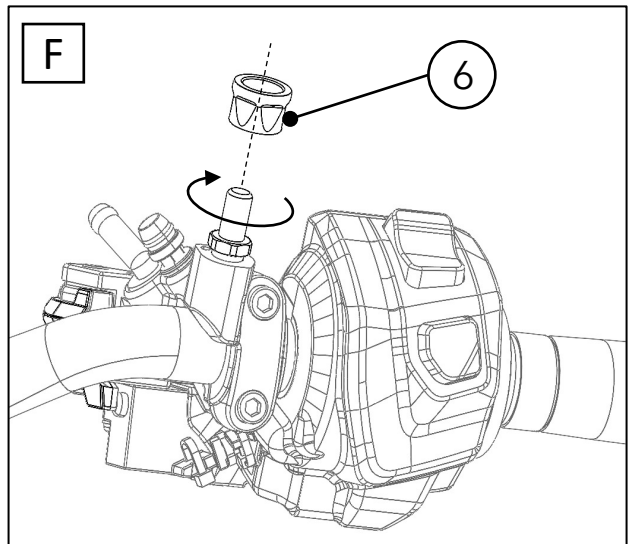
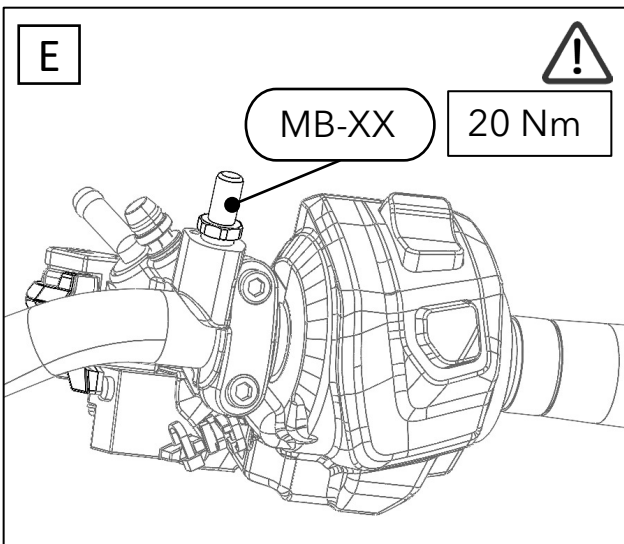
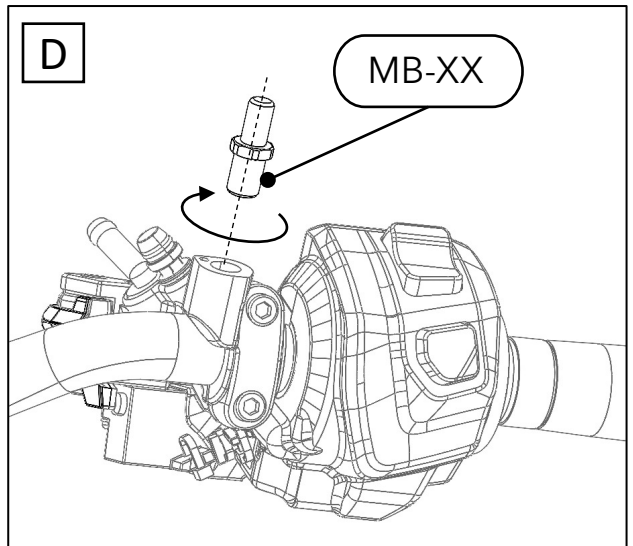
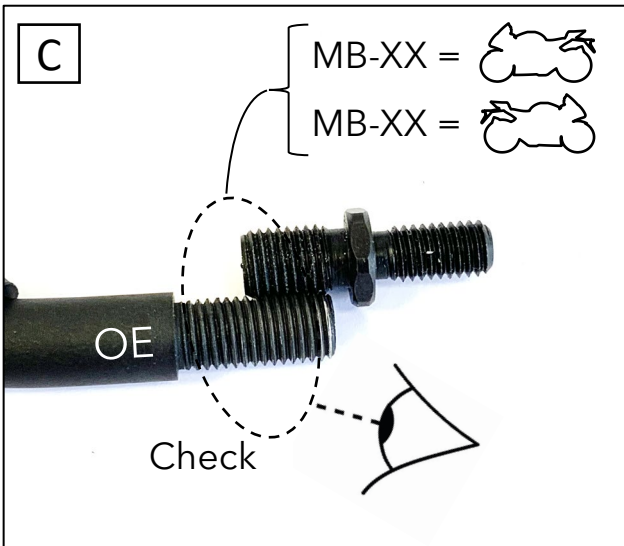
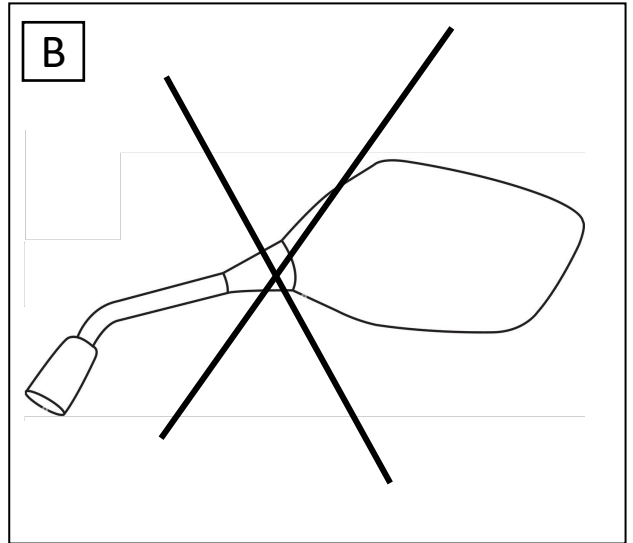
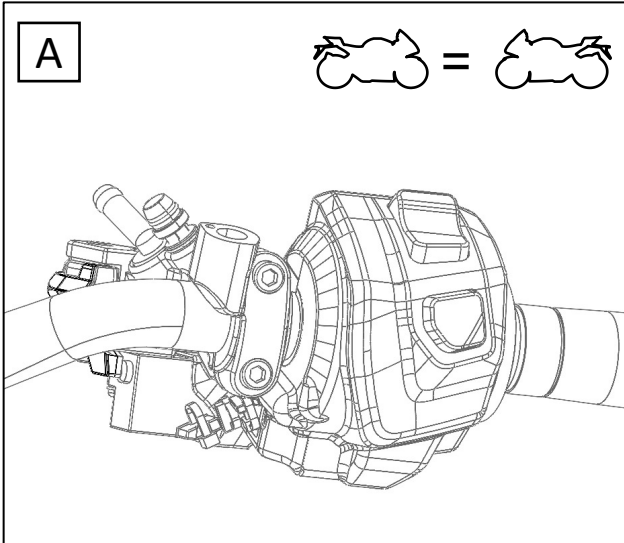

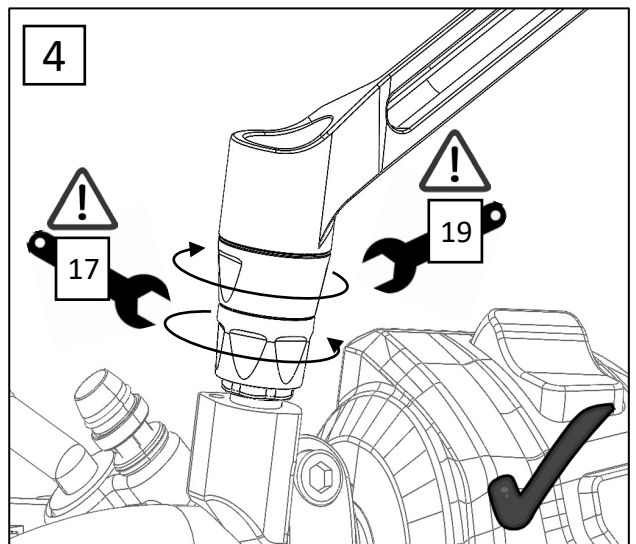
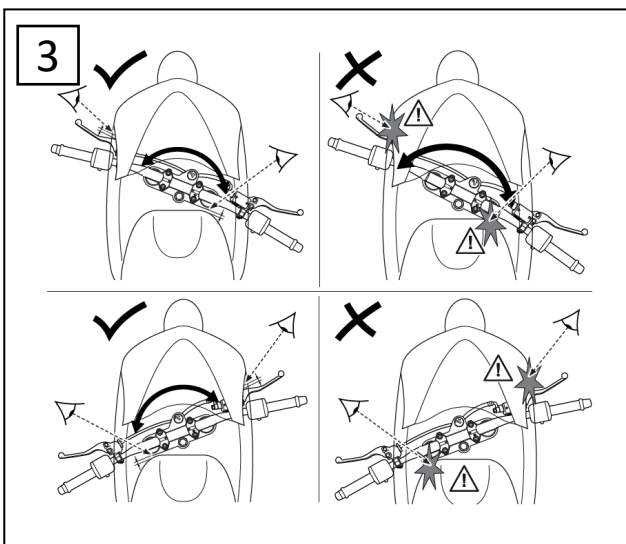
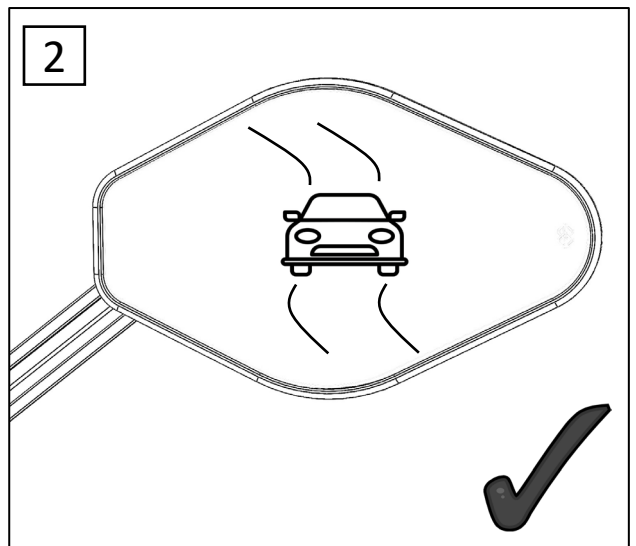
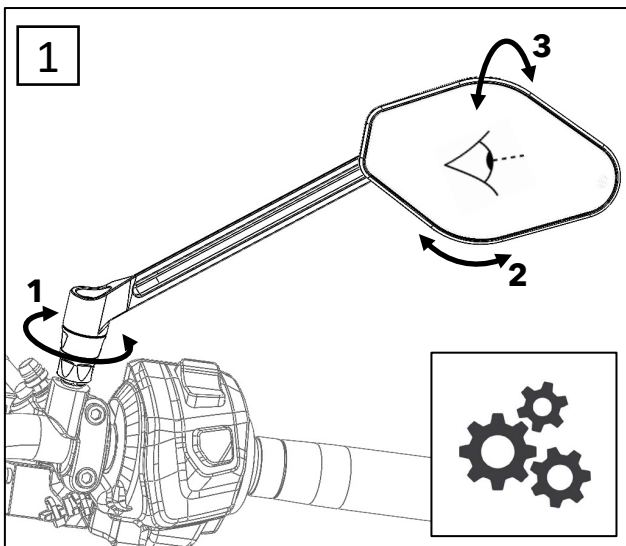
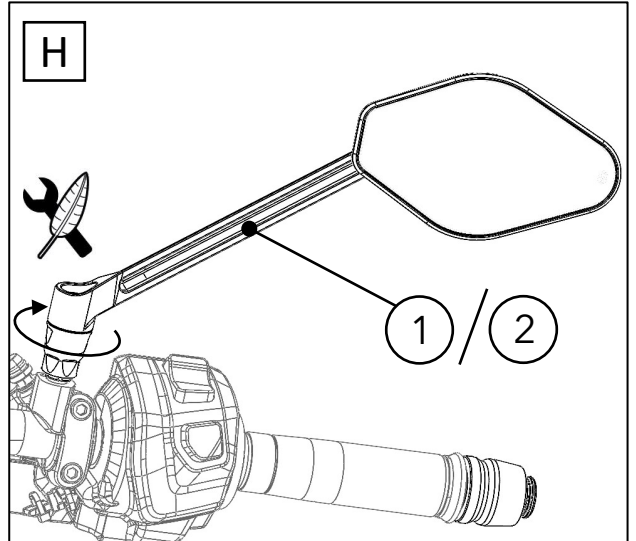
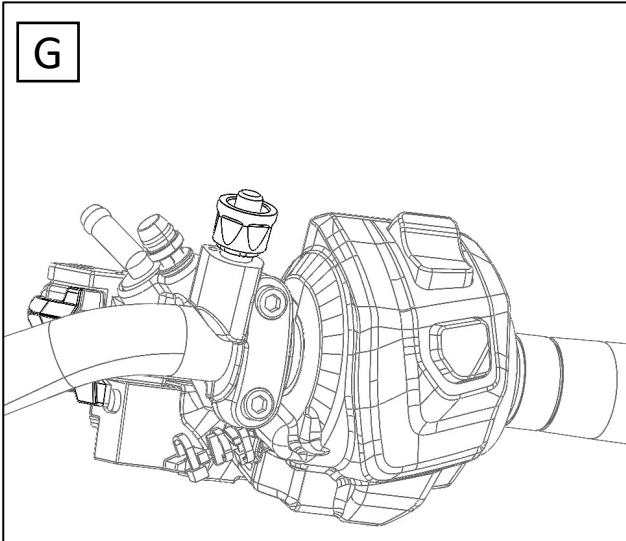



**GILLES Tooling GmbH**

26, Op der Ahlkerrech

L-6776 Grevenmacher

Luxembourg

[www.gillestooling.com](http://www.gillestooling.com)

