

Note!

Before installing this product, check the contents of the kit. If anything is missing, please check an Öhlins dealer.

Kit Contents

Description	Part No	Pcs
Shock absorber	YA 010	2
Screw M8x35	00432-01	2
Tool preload adjuster	03199-03	1
Sticker set "ÖHLINS"	10207-01	1
Owners manual	07241-02	1

Alternative spring

Spring	60240-04	2
--------	----------	---

Note!

Please note that this image is a general representation of the product and may differ slightly from your product.

Note!

Please note that during storage and transportation, especially at high ambient temperature, some of the oil and grease used for assembling may leak and stain the packaging. This is in no way detrimental to the product, wipe off the excessive oil/grease with a cloth.

Warning!

Before installing this product, read the Öhlins Owner's Manual. The shock absorber is an important part of your vehicle and will affect the stability.

Shock Absorber for YAMAHA N-Max 155/2020

YA 010

Mounting Instructions

MOUNTING INSTRUCTIONS

⚠ Warning!

It is advisable to have an Öhlins dealer install the shock absorber.

⚠ Warning!

If working on a raised vehicle, ensure it is securely supported so that it will not tip over.

👁 Note!

Before mounting this product clean the vehicle thoroughly.

👁 Note!

When working on this product, always see the Vehicle Service Manual for vehicle specific procedures and important data.

1

Put the motorcycle on a work stand so that the rear wheel barely touches the ground. Make sure the motorcycle is in a stable position.

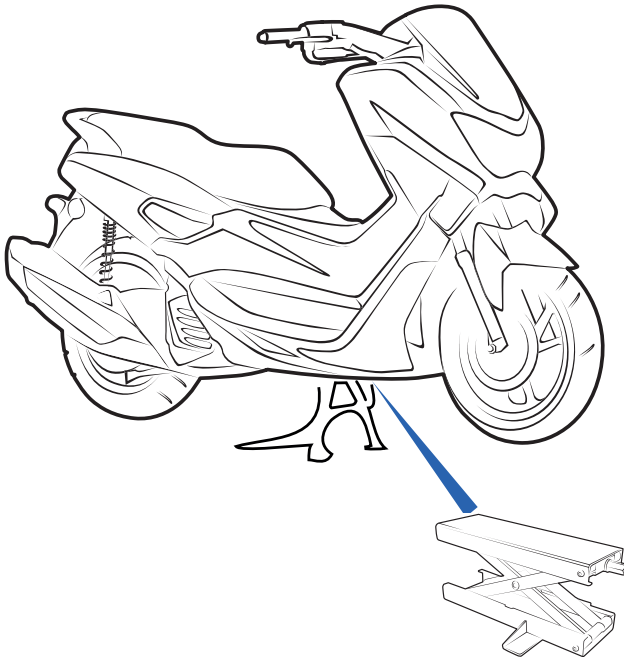

MOUNTING INSTRUCTIONS

2

On the left side : Remove the standard shock absorber by loosening the upper mounting nut ① and the lower mounting screw ②

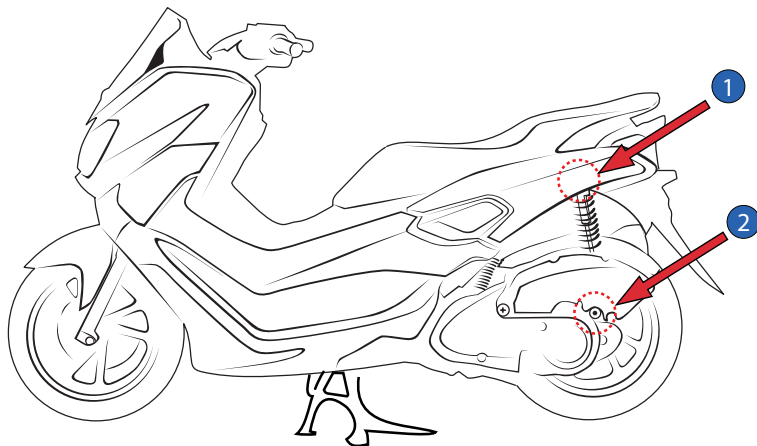

3

On the right side : Remove the exhaust muffler by loosening the screws ①②③④⑤ in order to access the right side shock absorber lower mounting screw.

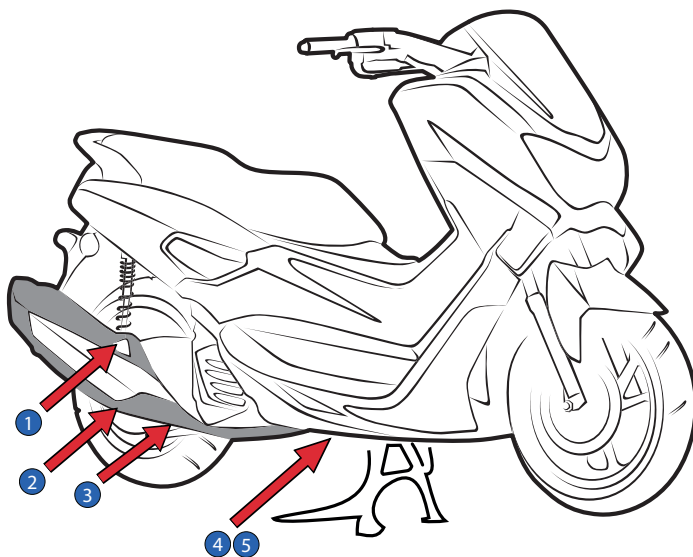

MOUNTING INSTRUCTIONS

4.

Install the Öhlins shock absorber according to diagram P1

Tighten the upper mounting nuts ① and the lower mounting screws ② at a torque value as specified in the vehicle service manual.

Reverse all the procedures as necessary.

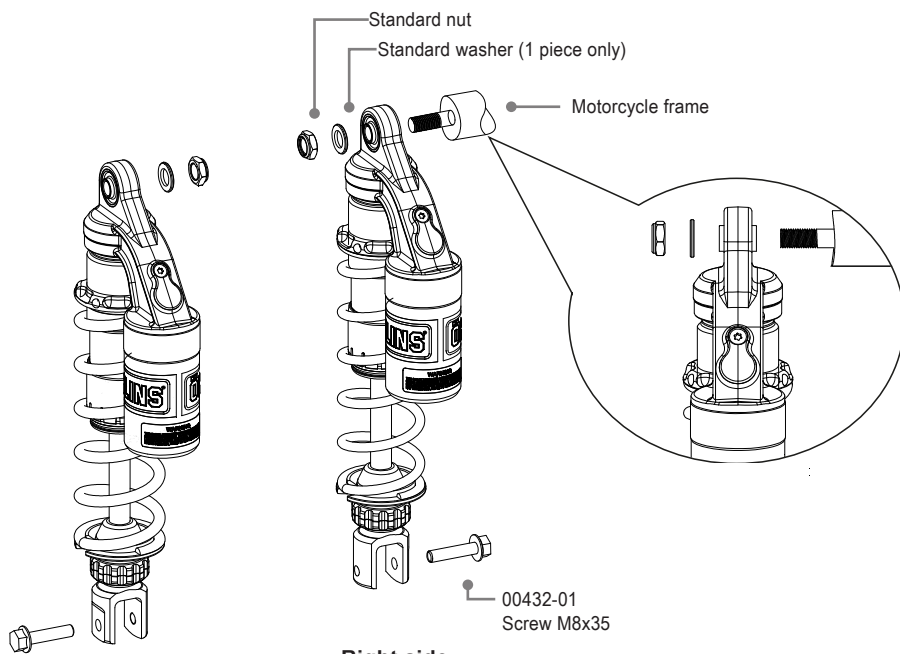
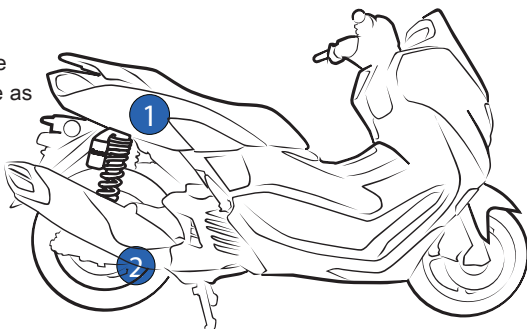

Left side

Right side

P1

Note!

Lower the vehicle so that the suspension is slightly compressed before tightening the screws.

Caution!

Ensure that all screws are tightened to the correct torque and that nothing fouls or restricts movement of the shock absorber when the suspension is fully compressed or extended.

This page intentionally left blank

This page intentionally left blank

This page intentionally left blank

ADJUSTMENTS

⚠ Warning!

Before riding, always make sure that the basic settings made by Öhlins are according to recommended Set-up Data. Read about adjustments and setting up in the Öhlins Owner's Manual before you make any adjustments. Contact an Öhlins dealer if you have any questions about setting up.

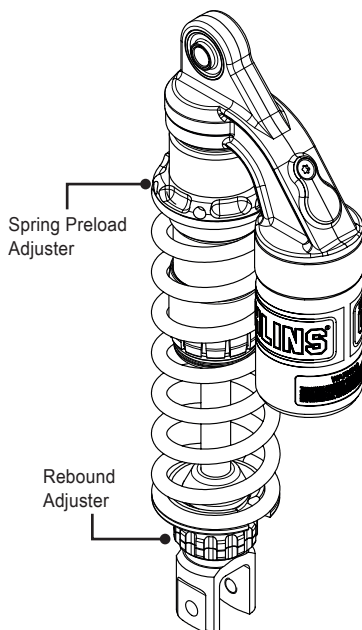

SET-UP DATA

Recommended set-up

Spring Preload..... 3 mm.
Rebound adjuster 16 Clicks

Shock absorber data

Length 314.5 mm.
Stroke 84.5 mm.

Spring

Part No 60240-03
Free spring length... 180 mm
Spring rate..... Prog 14-21 N/mm
Preload adj.range.... [0-12] mm

Installed spring (Medium)

Alternative spring (Hard)

60240-04
180 mm
Prog 16-25 N/mm
[0-12] mm

👁 Öhlins products are subject to continuous improvement and development, therefore, although these instructions include the most up-to-date information available at the time of printing, minor updates may occur.

To find the latest information contact an Öhlins distributor. Please contact Öhlins if you have any questions regarding the contents in this document.

Part no. MI_YA 010_EN_0
Issued 2020-03-02

© Öhlins Asia Co. Ltd. All rights reserved. Any reprinting or unauthorized use without the written permission of Öhlins Racing AB is prohibited.

Öhlins Asia Co. Ltd
700/937 Moo5, Tambol Nongkhaga,
Amphur Phantong, Chonburi Province
20160 Thailand



www.ohlins.com