

Kit Contents

Description	Part No	Pcs
Shock absorber	TR 964	2
Washer 14.1/24/3	03118-01	4
Tool preload adjuster	03199-01	1
Sticker "Memo notes"	01180-01	1
Sticker set R&T	10207-01	1
Owners manual	07241-02	1

Note!

Please note that this image is a general representation of the product and may differ slightly from your product.

Note!

Please note that during storage and transportation, especially at high ambient temperature, some of the oil and grease used for assembling may leak and stain the packaging. This is in no way detrimental to the product, wipe off the excessive oil/grease with a cloth.

Note!

Before installing this product, check the contents of the kit. If anything is missing, please contact an Öhlins dealer.

Warning!

Before installing this product, read the Öhlins Owner's Manual. The shock absorber/front fork/steering damper is an important part of your vehicle and will affect the stability.

Shock absorber for Triumph

TR 964

Mounting Instructions

MOUNTING INSTRUCTIONS

⚠ Warning!

It is advisable to have an Öhlins dealer install the shock absorber/front fork/steering damper.

⚠ Warning!

If working on a raised vehicle, ensure it is securely supported so that it will not tip.

👁 Note!

Before mounting this product clean the vehicle thoroughly.

👁 Note!

When working on this product, always see the Vehicle Service Manual for vehicle specific procedures and important data.

1

Put the motorcycle on a workstand so that the rear wheel barely touches the ground.

2

Loosen and remove the original shock absorbers.

3

Install the Öhlins shock absorbers in the same way as the original units, with the cylinder head up. If necessary, use the washers provided in this kit.

👁 Note!

Lower the vehicle so that the suspension is slightly compressed before tightening the screws.

👉 Caution!

Ensure that all screws are tightened to the correct torque and that nothing fouls or restricts movement of the shock absorber/front fork/steering damper when the suspension is fully compressed or extended.

👉 Caution!

The drive belt tension shall only be adjusted when the original shock absorber is installed on the vehicle.

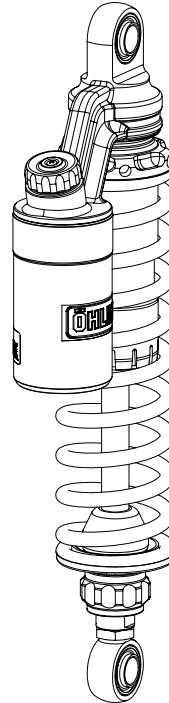

MOUNTING INSTRUCTIONS

ADJUSTMENTS

⚠ Warning!

Before riding, always make sure that the basic settings made by Öhlins are according to recommended Set-up Data. Read about adjustments and setting up in the Öhlins Owner's Manual before you make any adjustments. Contact an Öhlins dealer if you have any questions about setting up the shock absorber.

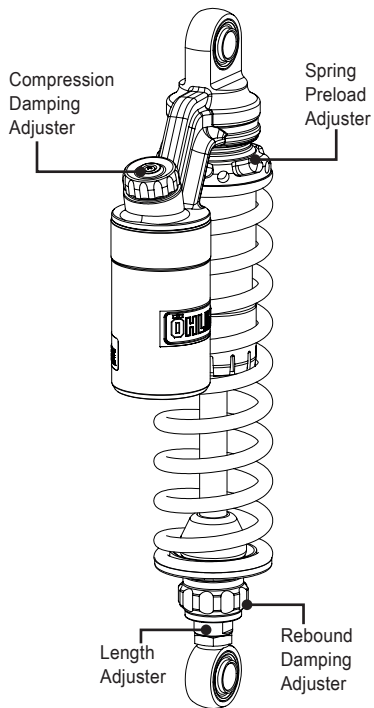
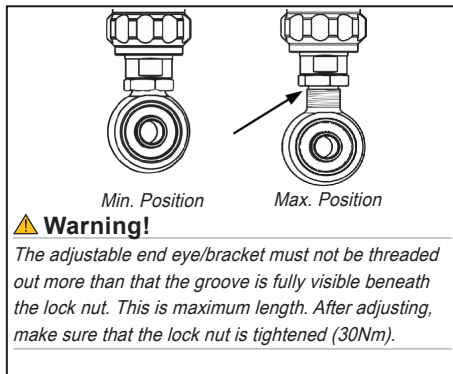

SET-UP DATA

Recommended set-up

Spring Preload.....	17 mm.
Compression adjuster.....	15 Clicks
Rebound adjuster	20 Clicks

Spring

Part No	60480-03
Free spring length.....	230 mm.
Spring rate.....	Prog. 18-27 N/mm
Preload adj.range.....	[0-31] mm

Shock absorber data

Length	369 ⁺¹⁰ / ₀ mm.
Stroke	99 mm.

👁 Öhlins products are subject to continuous improvement and development, therefore, although these instructions include the most up-to-date information available at the time of printing, minor updates may occur.

To find the latest information contact an Öhlins distributor. Please contact Öhlins if you have any questions regarding the contents in this document.

Part no. MI_TR 964_6
Issued 2018-07-13

© Öhlins Asia Co. Ltd. All rights reserved. Any reprinting or unauthorized use without the written permission of Öhlins Racing AB is prohibited.

Öhlins Asia Co. Ltd
700/937 Moo5, Tambol Nongkhaga,
Amphur Phantong, Chonburi Province
20160 Thailand



www.ohlins.com