



#### Kit Contents

Description	Part No	Pcs
Shock absorber	SU503	1
Sticker memo notes	01180-01	1
Sticker set Öhlins		1
Owner's manual	07241-02	1

#### Note!

Please note that this image is a general representation of the product and may differ slightly from your product.

#### Note!

Please note that during storage and transportation, especially at high ambient temperature, some of the oil and grease used for assembling may leak and stain the packaging. This is in no way detrimental to the product, wipe off the excessive oil/grease with a cloth.

#### Note!

Before installing this product, check the contents of the kit. If anything is missing, please contact an Öhlins dealer.

#### Warning!

Before installing this product, read the Öhlins Owner's Manual. The shock absorber/front fork/steering damper is an important part of your vehicle and will affect the stability.

## Shock absorber for Suzuki GSX-R 1000

# **SU 503**

## Mounting Instructions

# MOUNTING INSTRUCTIONS

## ⚠ Warning!

*It is advisable to have an Öhlins dealer install the shock absorber/front fork/steering damper.*

## ⚠ Warning!

*If working on a raised vehicle, ensure it is securely supported so that it will not tip.*

## 👁 Note!

*Before mounting this product clean the vehicle thoroughly.*

## 👁 Note!

*When working on this product, always see the Vehicle Service Manual for vehicle specific procedures and important data.*

1

Put the motorcycle on a workstand so that the rear wheel barely touches the ground.

2

Loosen and remove the rear attachment screws of the lower fairing so that the fairing can be devided.

3

Loosen the rear brake cylinder by removing the protective plate.

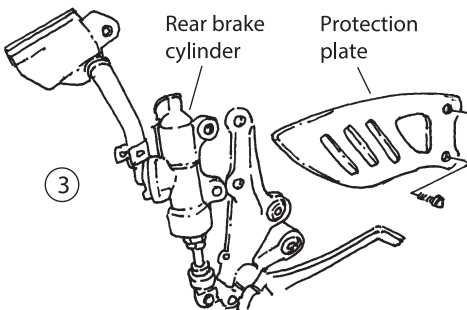

4

Loosen the brake fluid reservoir and remove the voltage regulator located above the shock absorber.

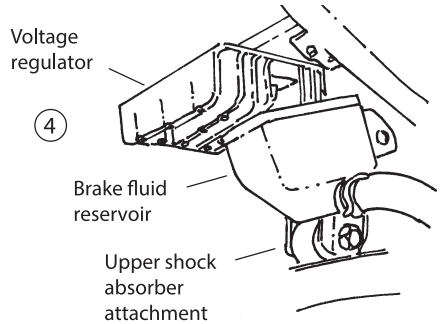

5

Loosen first the lower shock absorber attachment then the upper.

6

Remove the shock absorber through the top and towards the rear.

7

Install the Öhlins shock absorber by lifting it in position from above.

8

Attach the upper and the lower bracket of the shock absorber.

9

Reinstall the voltage regulator, brake cylinder and the lower fairing.

## 👁 Note!

*Lower the vehicle so that the suspension is slightly compressed before tightening the screws.*

## 👉 Caution!

*Ensure that all screws are tightened to the correct torque and that nothing fouls or restricts movement of the shock absorber/front fork/steering damper when the suspension is fully compressed or extended.*

# MOUNTING INSTRUCTIONS

# ADJUSTMENTS

## ⚠ Warning!

Before riding, always make sure that the basic settings made by Öhlins are according to recommended Set-up Data. Read about adjustments and setting up in the Öhlins Owner's Manual before you make any adjustments. Contact an Öhlins dealer if you have any questions about setting up.

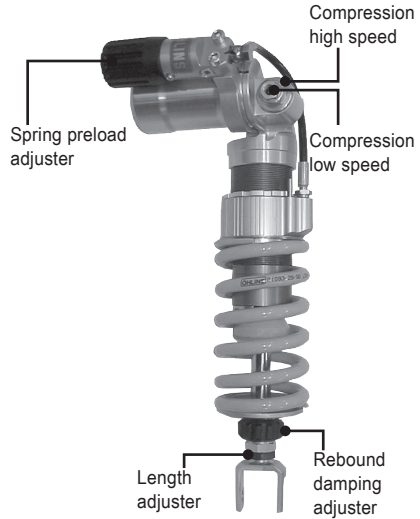

## SET-UP DATA

Length	325 <sup>+6%</sup>	mm
Stroke	70	mm
Rebound	14	clicks
Compr high speed	30	clicks
Compr low speed	12	clicks
Spring preload	8	mm

👁 Öhlins products are subject to continuous improvement and development, therefore, although these instructions include the most up-to-date information available at the time of printing, minor updates may occur.

To find the latest information contact an Öhlins distributor. Please contact Öhlins if you have any questions regarding the contents in this document.

Part no. MI\_SU503\_1  
Issued 2017-01-01



© Öhlins Racing AB. All rights reserved. Any reprinting or unauthorized use without the written permission of Öhlins Racing AB is prohibited.

Öhlins Racing AB  
Box 722  
S-194 27 Upplands Väsby, Sweden  
Phone +46 8 590 025 00  
fax +46 8 590 025 80



[www.ohlins.com](http://www.ohlins.com)