

Kit Contents

Description	Part No	Pcs
Shock absorber	KA467	1
Tie rap	00231-01	3
Sticker Memo notes	01180-01	1
Sticker set Öhlins		1
Owner's manual	07242-07	1

👁 Note!

Please note that there can be small differences between your product and the images in these instructions.

👁 Note!

Please note that during storage and transport, especially at high ambient temperature, some of the oil and grease used for assembly may leak and stain the packaging. This will not cause damage to the product, wipe off the excessive oil or grease with a cloth.

👁 Note!

Before you install this product, check the kit contents. If anything is missing, please contact an Öhlins dealer.

⚠ Warning!

Before you install this product, read the Öhlins Owner's manual. This product is an important part of the vehicle and the vehicle stability.

Shock absorber for Kawasaki ZX 6 R (636)

KA 467

Mounting Instructions

MOUNTING INSTRUCTIONS

⚠ Warning!

We strongly recommend to let an Öhlins dealer install this product.

⚠ Warning!

If you work with a lifted vehicle, make sure that it is safely supported to prevent it from tipping over.

👁 Note!

When you work with this product, see the vehicle service manual for vehicle specific procedures and important data.

👁 Note!

Before you install this product clean the vehicle.

1

Put the motorcycle on a work stand so that the rear wheel barely touches the ground.

2

Loosen the lower rear part of the fairing, on the left and the right side.

3

Remove the silencer and the pre silencer.

4

Remove the lower attachment of the original shock absorber.

5

Remove the bolt that connects the pull rods to the triangle link in the suspension linkage.

6

Remove the upper attachment, and remove the original shock absorber.

7

Install the Öhlins shock absorber. Do not tighten the attachment bolts yet.

8

Install the bolt for the pull rod and triangle link.

9

Tighten the upper and the lower attachments and the linkage bolts to the correct torque according to the Kawasaki specs.

10

Install the silencer.

11

Install the hydraulic preload adjuster on the inside of the silencer bracket. Remove one of the washers. Make sure the nut locks properly. Use the original bolt and nut. Fasten the hose with the tie raps provided in this kit.

12

Install all removed parts in the same positions as they were before removal.

👁 Note!

Lower the vehicle so that the suspension is slightly compressed before you tighten the screws.

👉 Caution!

Make sure that you tighten all screws to the correct torque and that nothing fouls or restricts movement of the shock absorber/front fork/steering damper when the suspension is fully compressed or extended.

MOUNTING INSTRUCTIONS

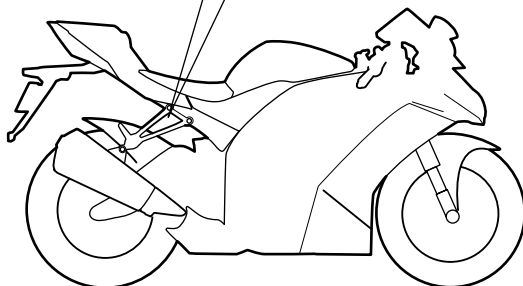
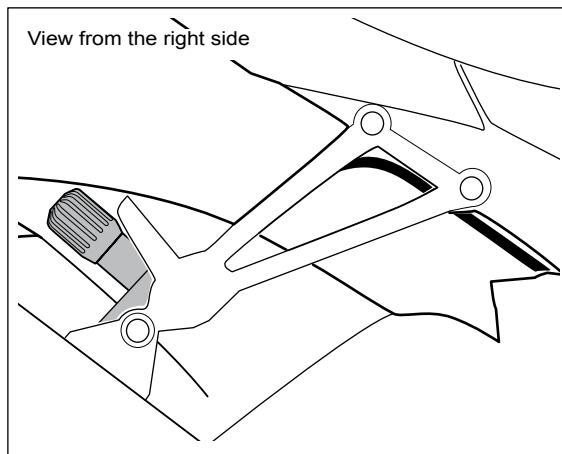
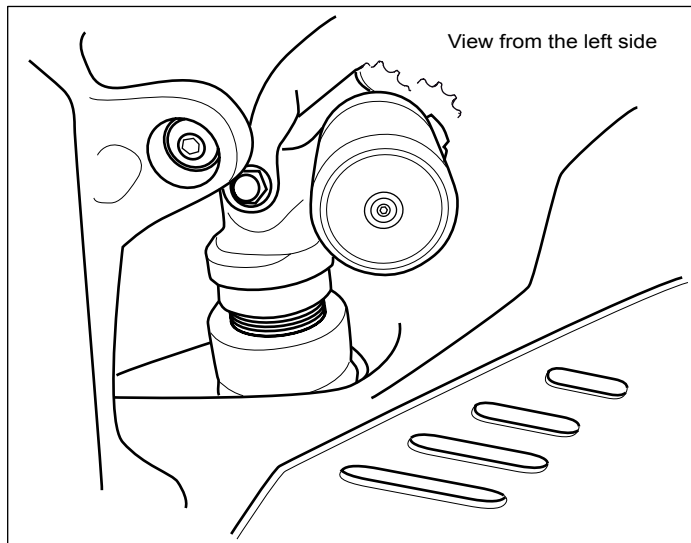

ADJUSTMENTS

⚠ Warning!

Before you ride/drive, always make sure that the setup is according to the recommended setup data. Read about adjustments and setting up in the Öhlins Owner's Manual before you make any adjustments. Contact an Öhlins dealer if you have any questions about setting up.

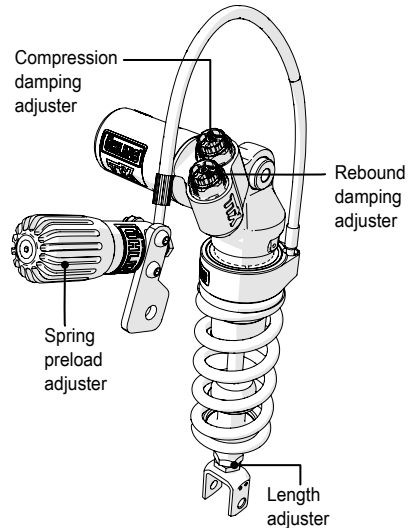

SETUP DATA

Length	341 +2/-4	mm
Stroke	64	mm
Rebound	14	clicks
Compression	12	clicks
Spring preload	10	mm
Spring	21040-36	
Spring rate	105	N/mm
Free spring length	160	mm

Recommended sag and ride height		
R1-R3	33	mm
F1-F3	40	mm

Öhlins products are subject to continuous improvement and development, therefore, although these instructions include the most up-to-date information available at the time of printing, minor updates may occur.

To find the latest information contact an Öhlins distributor. Please contact Öhlins if you have any questions regarding the contents in this document.

Part no. MI_KA467_0
Issued 2017-10-31

© Öhlins Racing AB. All rights reserved. Any reprinting or unauthorized use without the written permission of Öhlins Racing AB is prohibited.

Öhlins Racing AB
Box 722
S-194 27 Upplands Väsby, Sweden
Phone +46 8 590 025 00
fax +46 8 590 025 80



www.ohlins.com