

Note!

Before installing this product, check the contents of the kit. If anything is missing, please contact an Öhlins dealer.

Kit Contents

Description	Part No	Pcs
Shock Absorber	HO110030	1
Bracket reservoir	03102-15	1
Bracket	60006-07	1
Screw M6x12	01046-36	2
Screw M6x14	00382-16	1
C-spanner	00710-01	1
Sticker Öhlins	00192-01	2
Owners manual	07241-02	1

Note!

Please note that this image is a general representation of the product and may differ slightly from your product.

Note!

Please note that during storage and transportation, especially at high ambient temperature, some of the oil and grease used for assembling may leak and stain the packaging. This is in no way detrimental to the product, wipe off the excessive oil/grease with a cloth.

Warning!

Before installing this product, read the Öhlins Owner's Manual. The shock absorber is an important part of your vehicle and will affect the stability.

Shock Absorber for Honda CBR250R/300R

HO 717

Mounting Instructions



MOUNTING INSTRUCTIONS

⚠ Warning!

It is advisable to have an Öhlins dealer install the shock absorber.

⚠ Warning!

If working on a raised vehicle, ensure it is securely supported so that it will not tip over.

👁 Note!

Before mounting this product clean the vehicle thoroughly.

👁 Note!

When working on this product, always see the Vehicle Service Manual for vehicle specific procedures and important data.

1

Put the motorcycle on a work stand so that the rear wheel barely touches the ground. Make sure the motorcycle is in a stable position.

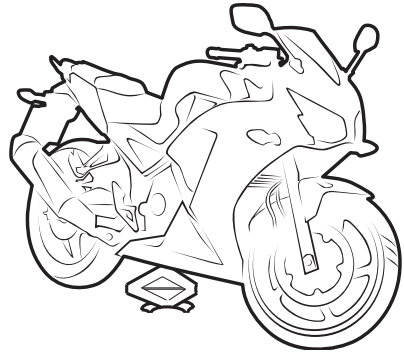

2

Remove the passenger seat by unlocking with the ignition key.

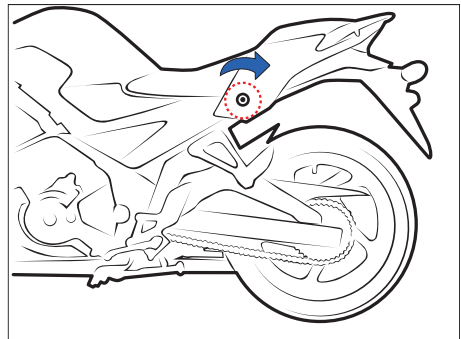

MOUNTING INSTRUCTIONS

3

Remove the driver seat by loosening the two screws (1)(2) and remove the grab bar by loosening the four screws (3)(4)(5)(6).

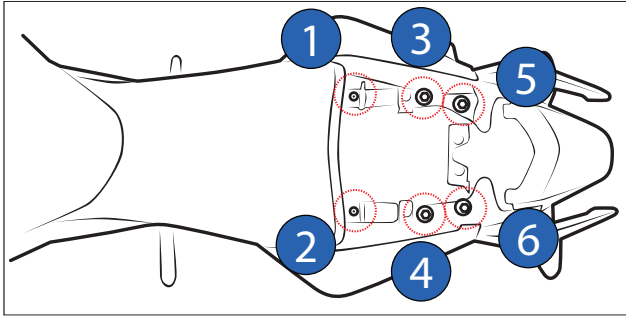

4

Remove the chain guard by loosening the four screws (1)(2)(3)(4).

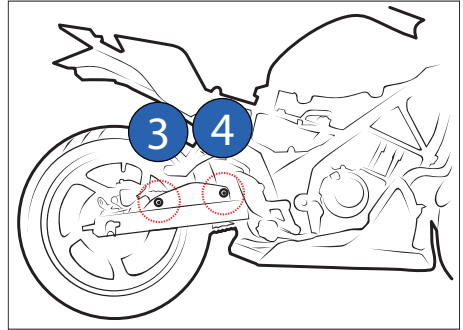
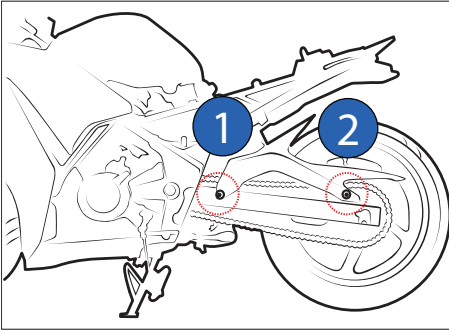

5

Remove the rear tail fender by loosening the two screws (1)(2).

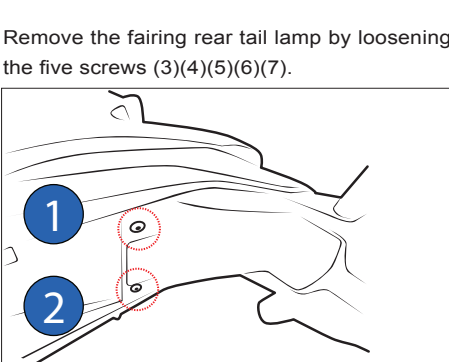

Remove the fairing rear tail lamp by loosening the five screws (3)(4)(5)(6)(7).

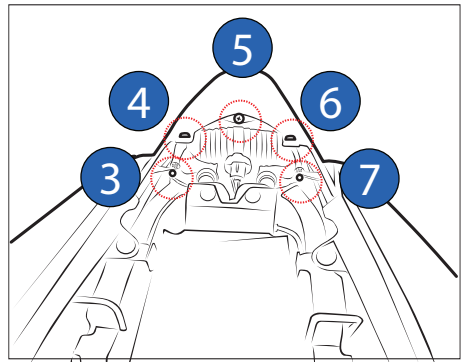

MOUNTING INSTRUCTIONS

6

Remove the taillamp by loosening the six screws (1)(2)(3)(4)(5)(6).

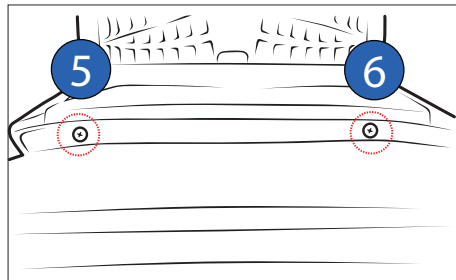
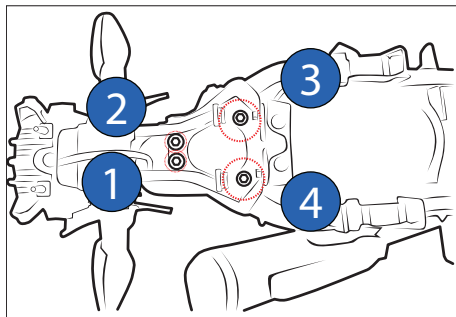

7

Release the front fairings on the left side by loosening the two screws (1)(2) and on the right side by loosening the three screws (3)(4)(5).

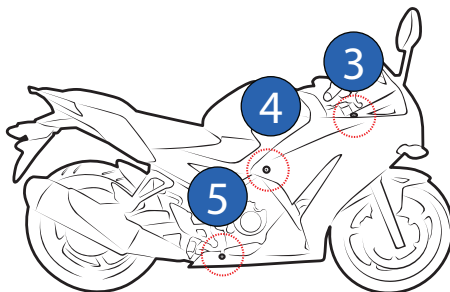
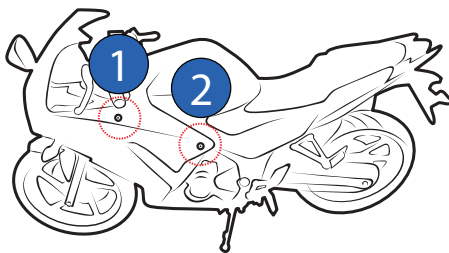

MOUNTING INSTRUCTIONS

8

Remove the center fairings on both sides by loosening the eight screws (1)(2)(3)(4)(5)(6)(7)(8).

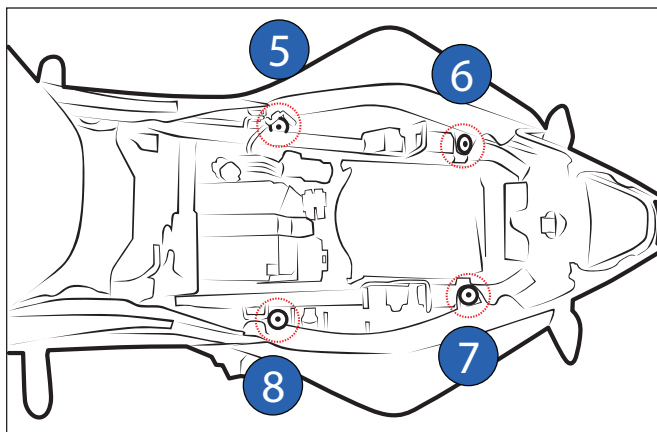
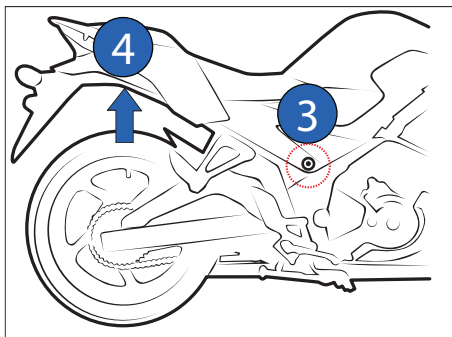
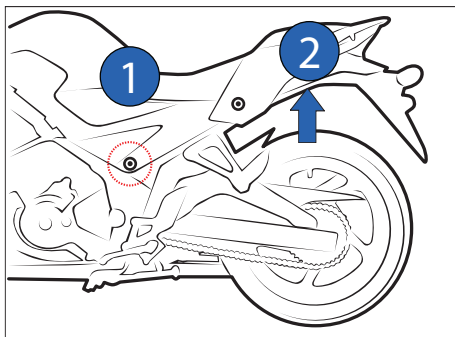

MOUNTING INSTRUCTIONS

9

Remove the cover of the ABS system by loosening the three screws (1)(2)(3).

⚠ Warning!

Do not force or damage the ABS system pipes.

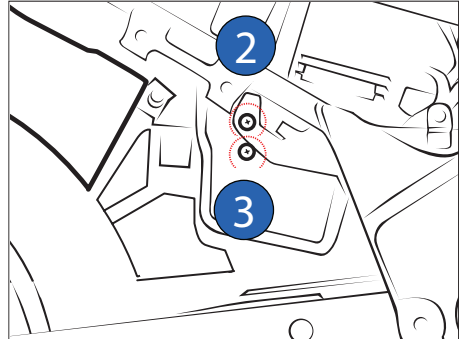
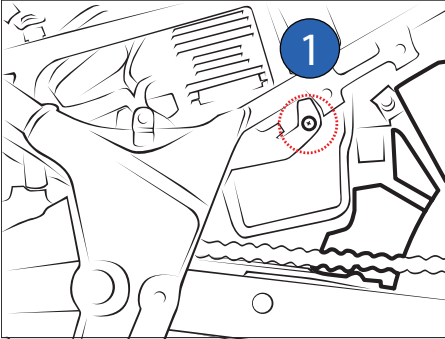

10

Release the linkage pull rod by loosening the bolt (1).

Remove the lower shock absorber mounting bolt (2).

Lower the swingarm as much as possible for access to the upper shock absorber bolt.

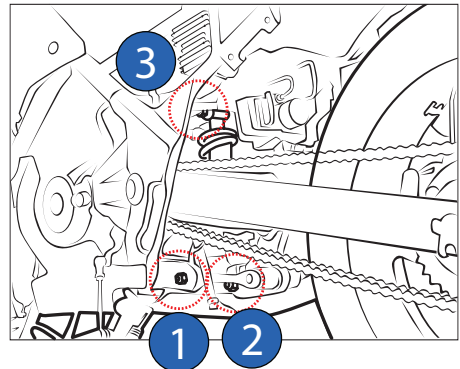

⚠ Warning!

During the lower of the swingarm make sure of not be pulling any hose, tube or cable.

MOUNTING INSTRUCTIONS

11

Install the Öhlins shock absorber with the hose and the reservoir hanging out on the left side of the motorcycle.

Tighten the upper and the lower shock absorber mounting bolts as per torque value specified in HONDA service manual.

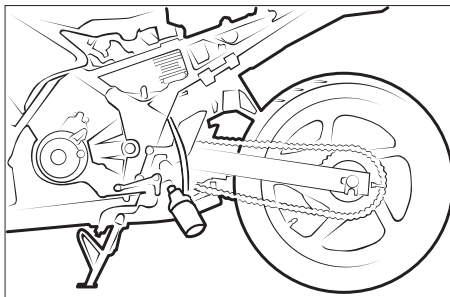

12

Remove the left footpeg bracket by loosening the two screws (1)(2).

Mount the bracket support under the footpeg and re-install it onto place by tightening the two screws (1)(2).

Install the reservoir into the reservoir bracket, Then fix the reservoir bracket onto the support bracket.

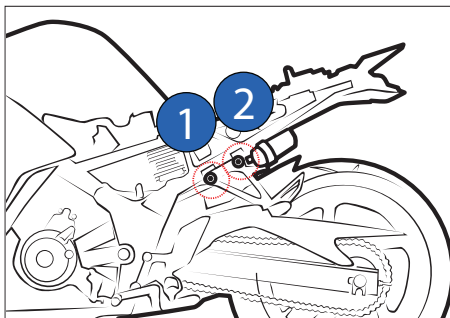

Reverse all procedures as required, tightening at torque value as specified in HONDA service manual.

Note!

Lower the vehicle so that the suspension is slightly compressed before tightening the screws.

Caution!

Ensure that all screws are tightened to the correct torque and that nothing fouls or restricts movement of the shock absorber when the suspension is fully compressed or extended.

ADJUSTMENTS

⚠ Warning!

Before riding, always make sure that the basic settings made by Öhlins are according to recommended Set-up Data. Read about adjustments and setting up in the Öhlins Owner's Manual before you make any adjustments. Contact an Öhlins dealer if you have any questions about setting up.

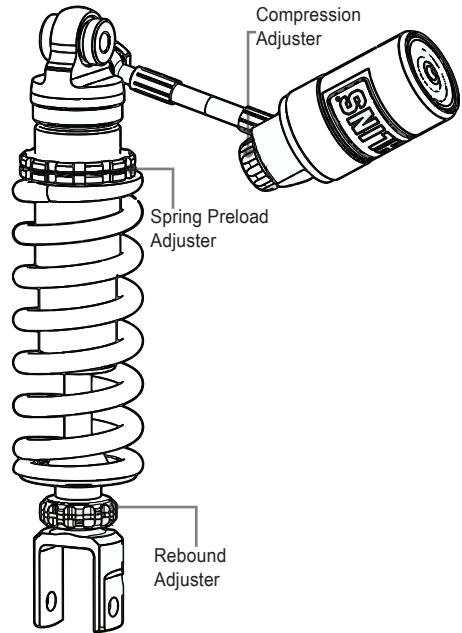

SET-UP DATA

Recommended set-up

Spring Preload	10 mm
Compression adjuster	12 Clicks
Rebound adjuster	22 Clicks

Shock absorber data

Length	297 mm
Stroke	54 mm

Spring

Part No	60281-11
Free spring length	165 mm
Preload adjustment range	[0-12]mm

👁 Öhlins products are subject to continuous improvement and development, therefore, although these instructions include the most up-to-date information available at the time of printing, minor updates may occur.

To find the latest information contact an Öhlins distributor. Please contact Öhlins if you have any questions regarding the contents in this document.

Part no. MI_HO 717_EN_1
Issued 2018-02-05

© Öhlins Asia Co. Ltd. All rights reserved. Any reprinting or unauthorized use without the written permission of Öhlins Racing AB is prohibited.

Öhlins Asia Co. Ltd
700/937 Moo5, Tambol Nongkhaka,
Amphur Phantong, Chonburi Province
20160 Thailand



www.ohlins.com