

Kit Contents

Description	Part No	Pcs
Shock absorber	HO 651	1
Bracket	01082-18	1
Reservoir bracket	03102-21	1
Screw M6x14	00382-52	1
Screw M6x12	05404-01	2
Screw M6x25	05404-06	2
Washer	00153-04	4
Tie-rap	00231-01	3
Sticker "Memo notes"	01180-01	1
Sticker set	10207-01	1
Owner's manual	07241-02	1

👁 Note!

Please note that there can be small differences between your product and the images in these instructions.

👁 Note!

Please note that during storage and transport, especially at high ambient temperature, some of the oil and grease used for assembly may leak and stain the packaging. This will not cause damage to the product, wipe off the excessive oil or grease with a cloth.

👁 Note!

Before you install this product, check the kit contents. If anything is missing, please contact an Öhlins dealer.

⚠ Warning!

Before you install this product, read the Öhlins Owner's manual. This product is an important part of the vehicle and the vehicle stability.

Shock absorber for Honda XL750 Transalp

HO 651

Mounting Instructions

MOUNTING INSTRUCTIONS

⚠ Warning!

We strongly recommend to let an Öhlins dealer install this product.

⚠ Warning!

If you work with a lifted vehicle, make sure that it is safely supported to prevent it from tipping over.

👁 Note!

When you work with this product, see the vehicle service manual for vehicle specific procedures and important data.

👁 Note!

Before you install this product clean the vehicle.

1

Put the motorcycle on a work stand or lift it so that the rear wheel barely touches the ground.

2

Remove the screw connecting the triangle link and pull rods.

3

Remove the lower and upper screw to the std shock absorber.

4

Remove the std shock absorber.

5

Mount the Öhlins shock absorber in reverse order with the hose to the left hand side.

👁 Note!

Lower the vehicle so that the suspension is slightly compressed before you tighten the screws.

6

Mount the Supplied bracket (01082-18) between the passenger foot peg mount and subframe, reuse OEM screws.

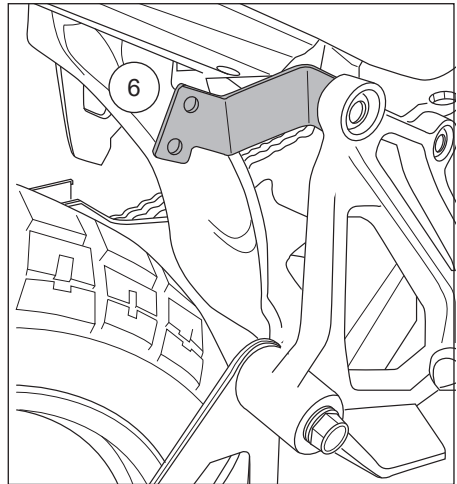
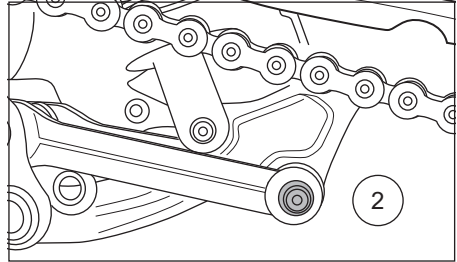

MOUNTING INSTRUCTIONS

7

Mount the supplied reservoir bracket (03102-21) to the reservoir and tighten slightly using M6x14 screw (00382-52). Use M6x25 screws (05404-06) and washers (00153-04) to mount the preload adjuster to the reservoir bracket. Then mount the whole unit using M6x12 screws (05404-01) and washers (00153-04) to fasten the reservoir bracket (03102-21) to the bracket (01082-18).

8

Position the reservoir according to the picture so the hose is not interfering with anything and clamp reservoir.

9

Use supplied tie-raps (00231-01) to fasten the hoses.

Caution!

Make sure that you tighten all screws to the correct torque and that nothing fouls or restricts movement of the shock absorber when the suspension is fully compressed or extended.

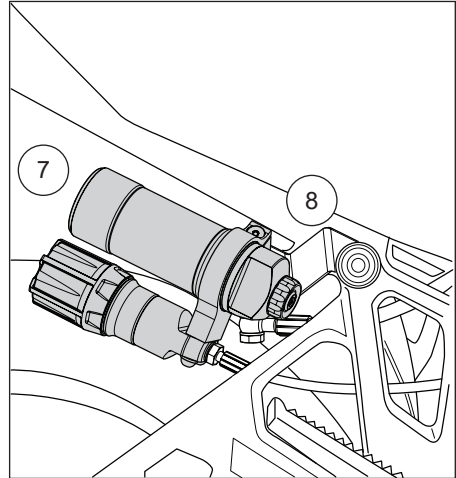

ADJUSTMENTS

⚠ Warning!

Before you ride/drive, always make sure that the setup is according to the recommended setup data. Read about adjustments and setting up in the Öhlins Owner's Manual before you make any adjustments. Contact an Öhlins dealer if you have any questions about setting up.

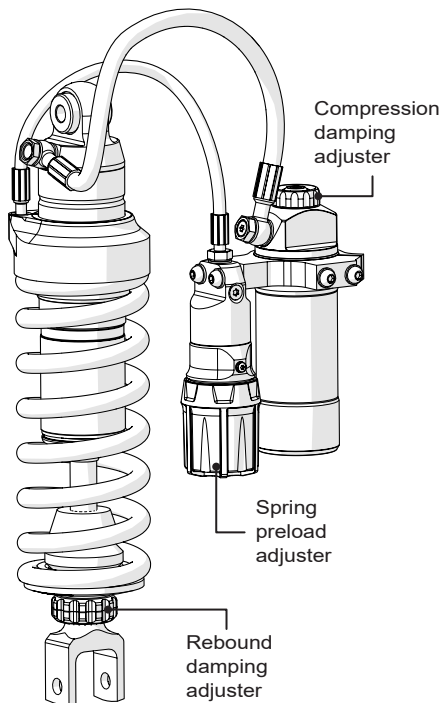

SETUP DATA

Length	347.5	mm
Stroke	76.5	mm
Rebound	10	clicks
Compression	10	clicks
Spring preload	6 +8/-2	mm

Recommended Free sag and Ride height

R1-R2		
R1-R3	88	mm
F1-F2		
F1-F3	63	mm

Recommended spring

01096-31 (95 N/mm)

Spring free length, 190 mm.

Öhlins products are subject to continuous improvement and development, therefore, although these instructions include the most up-to-date information available at the time of printing, minor updates may occur.

To find the latest information contact an Öhlins distributor. Please contact Öhlins if you have any questions regarding the contents in this document.

Part no. MI_HO651_0
Issued 2024-04-24

© Öhlins Racing AB. All rights reserved. Any reprinting or unauthorized use without the written permission of Öhlins Racing AB is prohibited.

Öhlins Racing AB
Box 722
S-194 27 Upplands Väsby, Sweden
Phone +46 8 590 025 00
fax +46 8 590 025 80



www.ohlins.com