

Kit Contents

Description	Part No	Pcs
Shock absorber	HO468	1
Sticker Memo notes	01180-01	1
Sticker set Öhlins		1
Owner's manual	07242-07	1

👁 Note!

Please note that there can be small differences between your product and the images in these instructions.

👁 Note!

Please note that during storage and transport, especially at high ambient temperature, some of the oil and grease used for assembly may leak and stain the packaging. This will not cause damage to the product, wipe off the excessive oil or grease with a cloth.

👁 Note!

Before you install this product, check the kit contents. If anything is missing, please contact an Öhlins dealer.

⚠ Warning!

Before you install this product, read the Öhlins Owner's manual. This product is an important part of the vehicle and the vehicle stability.

Shock absorber for Honda CBR 1000 RR

HO 468

Mounting Instructions

MOUNTING INSTRUCTIONS

⚠ Warning!

We strongly recommend to let an Öhlins dealer install this product.

⚠ Warning!

If you work with a lifted vehicle, make sure that it is safely supported to prevent it from tipping over.

👁 Note!

When you work with this product, see the vehicle service manual for vehicle specific procedures and important data.

👁 Note!

Before you install this product clean the vehicle.

Model year 2014-2016

1

Put the motorcycle on a work stand so that the rear wheel barely touches the ground.

2

Remove the fairing screw at the bottom.

3

Remove the lambda cable clip from the frame.

4

Remove the exup cable behind the rear brake fluid reservoir.

5

Be careful with the lambda and the exup cable. Loosen and move the silencer to the right.

6

Remove the shock absorber screws and the link screw from the swing arm.

7

Remove the original shock absorber downwards.

8

Install the Öhlins shock absorber.

9

Install all removed parts in the same positions that they were before removal.

👁 Note!

Lower the vehicle so that the suspension is slightly compressed before you tighten the screws.

👋 Caution!

Make sure that you tighten all screws to the correct torque and that nothing fouls or restricts movement of the shock absorber/front fork/steering damper when the suspension is fully compressed or extended.

Model year 2017-

1

Put the motorcycle on a work stand so that the rear wheel barely touches the ground.

2

Remove the fairing screw at the bottom.

3

Remove the plastig hugger in front of the rear wheel from the swing arm.

4

Remove the triangle link and pullrod from the swing arm, shock absorber and frame.

5

Remove the original shock absorber downwards.

6

Install the Öhlins shock absorber.

7

Install all removed parts in the same positions that they were before removal.

MOUNTING INSTRUCTIONS

Model year 2014-2016

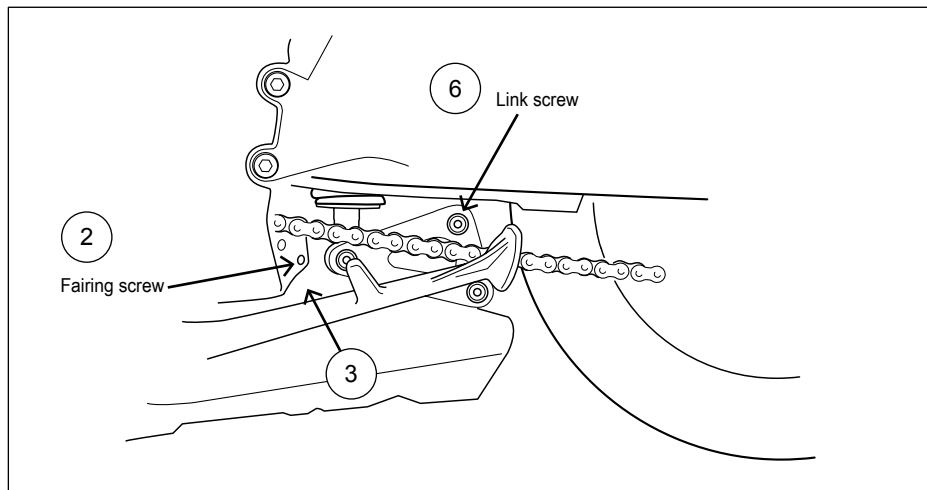

Model year 2017-

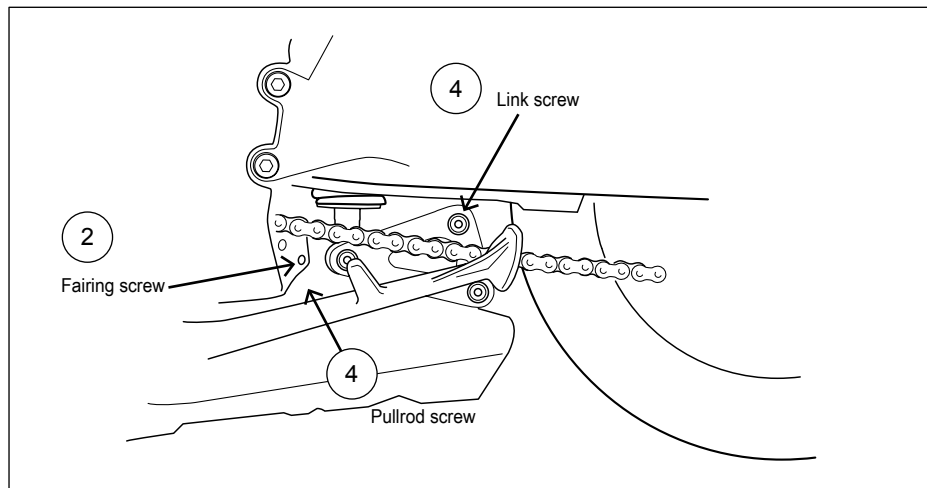

ADJUSTMENTS

⚠ Warning!

Before you ride/drive, always make sure that the setup is according to the recommended setup data. Read about adjustments and setting up in the Öhlins Owner's Manual before you make any adjustments. Contact an Öhlins dealer if you have any questions about setting up.

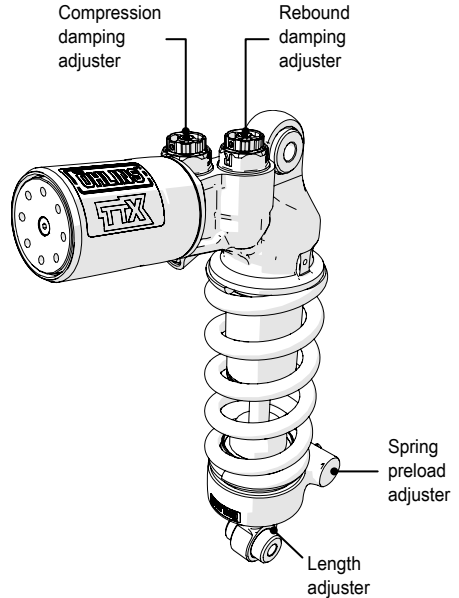

SETUP DATA

Length	302 +4/-2	mm
Stroke	60	mm
Rebound	13	clicks
Compression	10	clicks
Spring preload	14	mm
Spring	21040-36	
Spring rate	105	N/mm
Spring free length	160	mm

Recommended sag and ride height		
R1-R3	32	mm
F1-F3	41	mm

Öhlins products are subject to continuous improvement and development, therefore, although these instructions include the most up-to-date information available at the time of printing, minor updates may occur.

To find the latest information contact an Öhlins distributor. Please contact Öhlins if you have any questions regarding the contents in this document.

Part no. MI_HO468_0
Issued 2017-10-31

© Öhlins Racing AB. All rights reserved. Any reprinting or unauthorized use without the written permission of Öhlins Racing AB is prohibited.

Öhlins Racing AB
Box 722
S-194 27 Upplands Väsby, Sweden
Phone +46 8 590 025 00
fax +46 8 590 025 80



www.ohlins.com