



Öhlins Front Fork Pressurized Cartridge Kit

FKR 100-Series

Owner's Manual



Öhlins Headquarters Upplands Väsby, Sweden

Öhlins Racing AB - The Story

It was the 1970's, a young man named Kenth Öhlin spent most of his spare time pursuing his favourite sport: motocross.

Being a careful observer, Kenth's attention was continuously drawn to one specific detail - motocross bikes had more engine power than their suspension could handle. It was not long before Kenth realised that better performance could be achieved by improved wheel suspension.

Öhlins Racing was established in 1976, and just two years later the company won its first World Championship title and the search for perfection and new functions is still the main focus of the company.

Congratulations! You are now the owner of an Öhlins product. More than two hundred World Championships and other major world titles are definitive proof that Öhlins products offer outstanding performance and reliability.

Every product has gone through rigorous testing and engineers have spent thousands of hours, doing their very best to use every possible experience from our racing history.

The product that you now have in your possession is pure racing breed that is built to withstand.

By installing this product on your vehicle you have made a clear statement... you are a serious rider or driver with a focus on getting the maximal handling ability and outstanding feedback from your vehicle. Along comes the fact that your Öhlins product will be a long lasting friend, delivering the very best of comfort and performance every time you go for a ride. Go explore!

SAFETY PRECAUTIONS

General Warnings

Note!

The shock absorber/front fork/steering damper is an important part of the vehicle and will affect the stability.

Note!

Read and ensure you understand the information in this manual and other technical documents provided by Öhlins, before using the product.

Note!

Öhlins Racing AB can not be held responsible for any damage to the shock absorber/front fork/steering damper, vehicle, other property or injury to persons, if the instructions for mounting, usage and maintenance are not followed exactly.

Warning!

After installing the Öhlins product, take a test ride at low speed to ensure your vehicle has maintained stability.

Warning!

If the suspension makes an abnormal noise, or the function is irregular, or if you notice any leakage from the product, stop the vehicle immediately and return the product to an Öhlins dealer.

Warning!

The product warranty shall only apply if the product has been operated and maintained in accordance with recommendations in this manual. If you have any questions regarding usage, service, inspection and/or maintenance please contact Öhlins.

Warning!

This product was developed and designed exclusively for a specific vehicle model and shall only be installed on the intended vehicle model in its original condition as delivered from the vehicle manufacturer.

SAFETY SYMBOLS

In this manual, mounting instructions and other technical documents, important information concerning safety is distinguished by the following symbols:



The Safety Alert Symbol means: Warning! Your safety is involved.

Warning!

The Warning Symbol means: Failure to follow warning instructions can result in severe or fatal injury to anyone working with, inspecting or using the shock absorber, or to bystanders.

Caution!

The Caution Symbol means: Special precautions must be taken to avoid damage to the shock absorber.

Note!

The Note Symbol indicates information that is important regarding procedures.

Note!

When working with the Öhlins product, always read the vehicle service manual.

Note!

This manual shall be considered as a part of the product and shall accompany the product throughout its life cycle.

CONTENTS

1 Front Fork Cartridge Kit	5
2 Design and Function	6
3 Setting up your front fork.....	7
4 Adjustments	8
5 Change main spring and check or change front fork fluid level	11
6 Technical specifications.....	14
7 Inspection and maintenance	15



1 FRONT FORK CARTRIDGE KIT

Introduction

The product in your hand is an artwork, prepared by our dedicated craftsmen at our facility in Upplands Väsby, Sweden. Its predecessors have battled their way on numerous race tracks in World Superbike, Supersport, Superstock and AMA and the legacy continues in your front fork. Thousands of hours have been spent together with some of the best teams in the world to find the optimal design and functionality to give you as much performance, comfort and confidence as possible. You will feel the difference...be sure.

Design

The DNA of this new 25 mm front fork cartridge kit originates in the most prestigious race series in the world and the front fork cartridge kit is weight optimized as a result of that fact. We have used exclusive racing components

from our R&D department to increase the performance of the front fork cartridge kit. Our engineers that work on a daily basis with the top riders in the world often hear the word "feeling" and "control" when they debrief after tests and races.

We wanted to pour as much of these important factors into your front fork cartridge kit and, as a result, the new 25 mm front fork cartridge kit gives you improved "brake support" and "tire feel" when riding. For all of you that have your mind set on doing some serious racing we have some really good news.

Of course we have improved the design so that you easily can have it properly maintained and every kit is individually tested with an optimum setting and spring recommendation.



2 DESIGN AND FUNCTION

The front fork cartridge kit is divided into one compression cartridge and one rebound cartridge. The compression cartridge is installed in the left hand side front fork leg and the rebound cartridge in the right hand side front fork leg. Marked at the top cap is "COMP" for compression adjustment and "REB" for rebound adjustment.

The compression and rebound cartridges are both of the same design but works opposite each other. To achieve rebound damping force instead of compression damping force, the cylinder tubes and the pistons are turned opposite each other between the compression and the rebound cartridges.

When the front fork moves, the fluid inside is forced to flow through the pistons. At a compression movement the fluid is forced through the compression shim stack and at the same time through the rebound check valve. And opposite, at a rebound movement the fluid is forced through the rebound shim stack and through the compression check valve.

The fluid displaced by the piston shafts are directed into or out of the spaces between inner and outer cylinder tubes. That is in turn connected to a reservoir in the seal head.

The compression and the rebound pistons are both of the same design. The pistons have three flow paths for the fluid:

1. Bleed valve. Small orifice that creates a flow restriction simply by being small.
2. Shim valve. Fluid pressure has to deflect thin steel washers (shims) to open up an orifice and allow fluid to flow through it.
3. Check valve. A shim stack that opens easily, for return flow of fluid when the direction of movement of the front fork changes.

The bleed valve and shim valve are used to build up damping force. At slow stroke speeds the percentage going through the bleed valve is higher and at fast strokes the shim valve takes care of most of the flow.

The check valve, together with the bleed valve (since it can flow both directions), handle return flows.

To control damping force the bleed valve can be adjusted externally from the top cap on both compression and rebound.

By altering the stiffness of the shim stack (number, thickness, diameter and shape) on the shim valve the characteristics of the damping action can be changed. This should only be done by an authorized Öhlins service workshop.

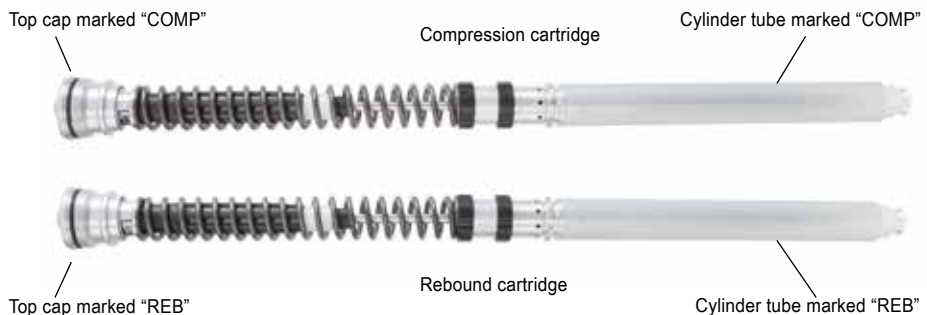

3 SETTING UP YOUR FRONT FORK

Measure sag

Main spring preload - Free sag - Ride height

The main spring preload directly affects the front fork angle and the motorcycle height. Therefore, when you setup your motorcycle the main spring preload should be one of the first things to check.

1. Perform this procedure on a flat surface.
2. Place the motorcycle on a work stand so that both wheels are off the ground and the suspension is unloaded.
3. Use a piece of tape and mark a point straight above the rear wheel axle.
4. Measure the distance from the marked point to a fixed point, for example the wheel axle (R1).
5. Measure the distance from the bottom of the upper triple clamp to a fixed point, for example the front wheel axle (F1).
6. Place the motorcycle on the ground so that the front and the rear suspension are slightly compressed.
7. Repeat the measure procedures (R2 and F2). Sit on the motorcycle in normal riding position and properly equipped in full riding gear. Repeat the measure procedure (R3 and F3).

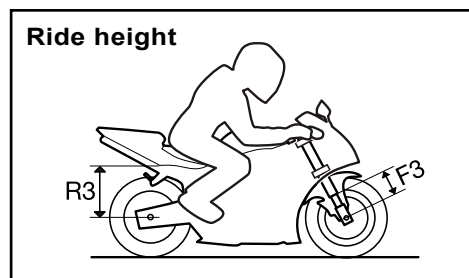
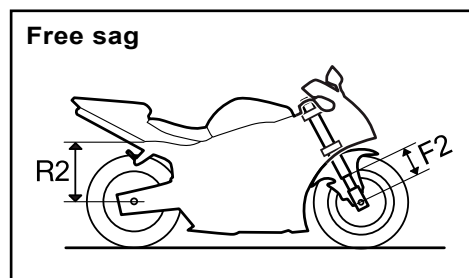
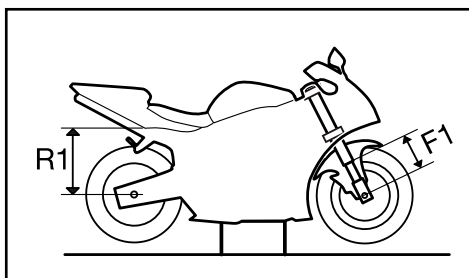

Note measures			
R1		F1	
R2		F2	
R3		F3	

Recommended measures

If no other recommendations are given in the Mounting instructions for your product, see the table below for recommended measures.

Sag pos.	Formula	Rec.
Free sag	$\frac{(F1-F2)}{\text{wheel travel}} \times 100$	~15-30 %
Ride height	$\frac{(F1-F3)}{\text{wheel travel}} \times 100$	~20-40 %

If the measures differ significantly you may need to adjust the main spring preload or change the springs. Please see the Mounting Instructions for your kit to find out more or contact an authorized Öhlins service center for advice.

⚠ Warning!

An incorrect main spring rate can give a faulty front geometry leading to under or over steering and seriously affect the ground clearance and vehicle handling.

4 ADJUSTMENTS

4.1 - Adjusters

• Main spring preload adjuster

Use a 14 mm wrench to turn the outer adjuster. Maximum adjustment range is 18 mm. Turn clockwise to increase and counterclockwise to decrease the preload. One turn corresponds to 1 mm change in preload

• Compression damping adjuster

Left hand side front fork leg.

• Rebound damping adjuster

Right hand side front fork leg.

Adjust Compression and Rebound;

Use a 3 mm hex key. Adjustment range from fully closed valve (clockwise) to fully open valve (counterclockwise) is about 25 "clicks". Recommended "clicks" from closed position according to your mounting instruction for your Front Fork Cartridge Kit.

4.2 - Main spring

The main springs recommended in the Mounting Instructions are chosen after evaluations performed on a test track according to motorcycle characteristics for your specific motorcycle model. Due to variations in ride style, track conditions, body shape etc. the main spring is often a subject for additional fine-tuning.

Main springs are available in 0.5 N/mm intervals but the rate can be set to 0.25 N/mm increments by using two different rates. A method used on the race track.

Example:

Using 9.5 N/mm in the right hand side front fork leg and 10.0 N in the left hand side front fork leg gives a combined main spring rate of 9.75 N/mm.

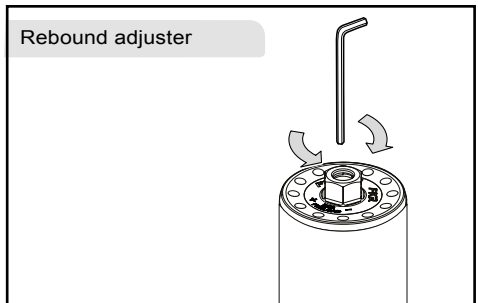
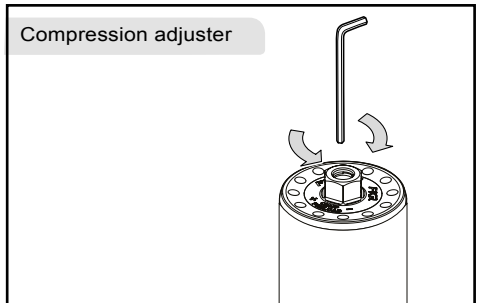
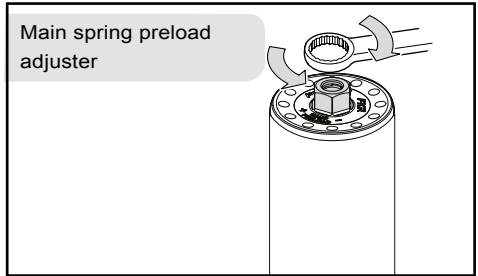

4 ADJUSTMENTS

4.3 - Front fork fluid level

⚠ Caution!

Use only Öhlins high performance suspension fluid (01309-xx).

Front fork fluid level diagram

The diagram below shows reaction force curves at two different fluid levels. A change in the fluid level will mainly affect the air spring force and rate at the end of the front fork travel.

High fluid level

The air spring in the later half stage of travel is stronger which makes the front fork firmer.

Low fluid level

The air spring in the later half stage of travel is lessened which makes the front fork more linear.

Adjust front fork fluid level

👁 Note!

When measuring fluid level, remove main spring and preload tube, make sure shaft assembly and outer tube are in their bottom positions. Measure fluid level with a ruler. See set-up data and front fork fluid level-force diagram in the Mounting Instructions.

The diagram in the Mounting Instructions shows several curves where each curve corresponds to a specific front fork fluid level. For recommended fluid level, see the Mounting Instructions. **If the Mounting Instructions was not included in your Front Fork Cartridge Kit, please contact an Öhlins dealer.**

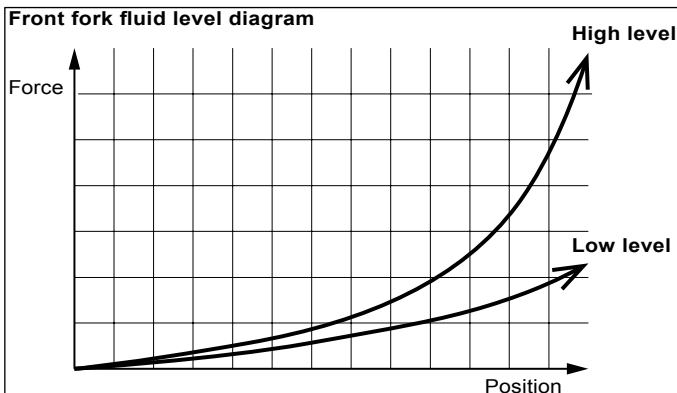
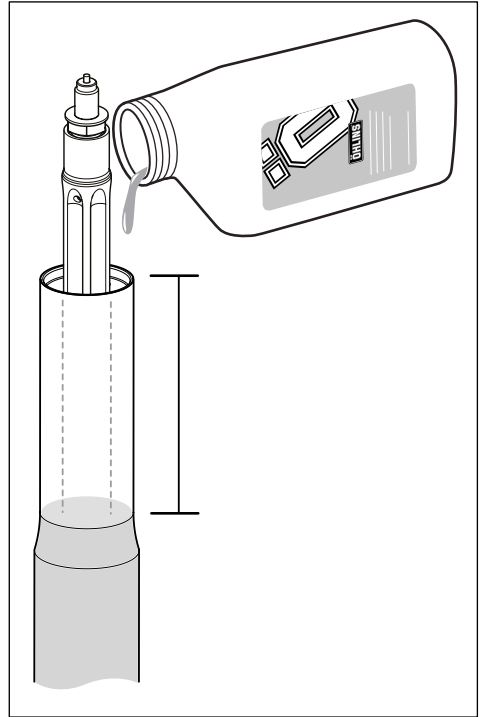

4 ADJUSTMENTS

4.4 - Front fork leg position

The front fork leg position changes the ride height at the front. To measure the front fork leg position; measure the distance between the outer tube and the upper triple clamp. For recommended front fork leg position, see the Mounting Instructions.

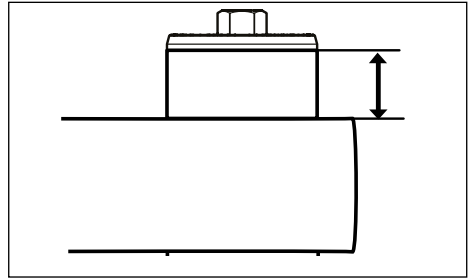

5 CHANGE MAIN SPRING AND CHECK OR CHANGE FRONT FORK FLUID LEVEL

⚠ Warning!

This procedure requires high technical knowledge and/or experience of working with front forks. If you feel any insecurity regarding this procedure, contact an Öhlins dealer for advice. See the Vehicle Service Manual.

⚠ Warning!

Spring compression creates a potential danger because of the violent force that loaded springs are capable of. Beware of this when you work with the front fork.

1

Put the motorcycle on a workstand so that the front wheel barely touches the ground.

⚠ Warning!

Make sure the vehicle is securely supported so that it will not fall over.

2

Remove the fender, brake calipers and front wheel.

3

Release the main spring preload by turning the adjuster counter clockwise until it stops. **[14 mm wrench]**.

4

Note the front fork leg position.

5

Loosen the upper triple clamp.

6

Loosen (do not remove) the top cap ½ turn. **[00797-08 top cap tool]**.

7

Loosen the lower triple clamp.

8

Remove the front fork legs from the triple clamps.

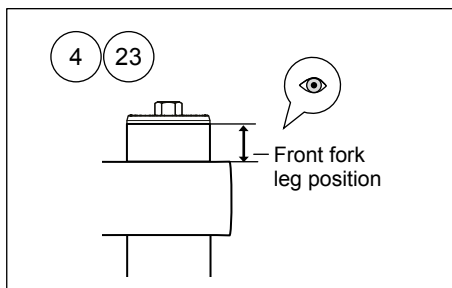
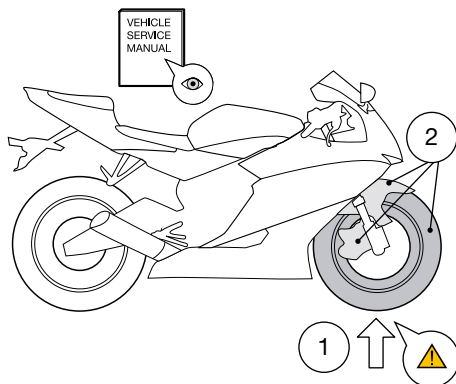

5 CHANGE MAIN SPRING AND CHECK OR CHANGE FRONT FORK FLUID LEVEL

9

Loosen top cap from outer tube. **[00797-08 top cap tool]**.

10

Loosen top cap and remove it from shaft extension. **[14 mm and 19 mm wrench]**.

11

Remove spring support, main spring and preload tube.

12

Measure front fork fluid level and adjust if necessary, see chapter 4.3.

13

Install tool on shaft extension **[01765-03 shaft extension tool]**.

14

Install preload tube, main spring and spring support **[main spring selection according to Mounting Instructions]**.

15

Pull up shaft assembly and insert tool in shaft extension **[19 mm wrench]**.

16

Remove shaft extension tool.

17

Make sure compression and rebound bleed and preload adjusters are fully opened, counterclockwise, before installing top cap.

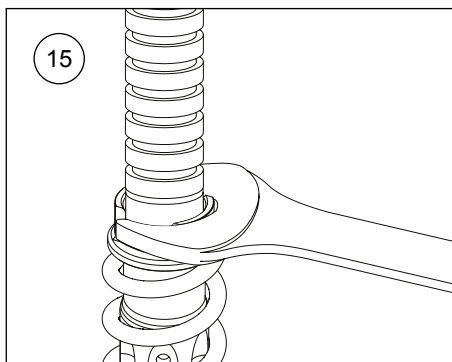
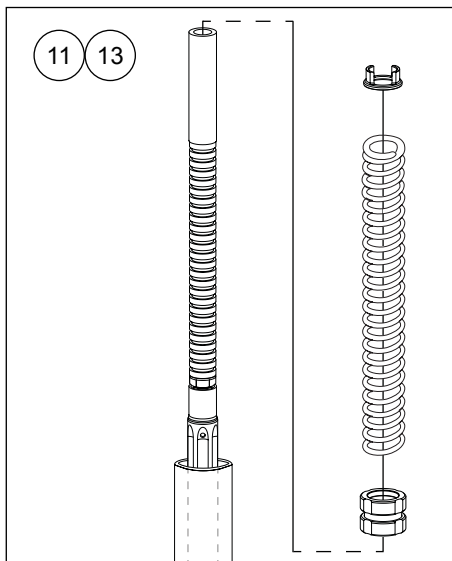
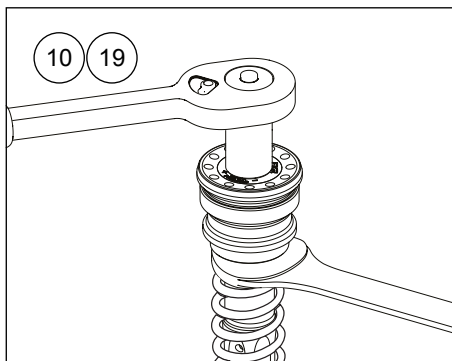

5 CHANGE MAIN SPRING AND CHECK OR CHANGE FRONT FORK FLUID LEVEL

19

Install top cap on shaft extension [**14 mm socket, torque 20 Nm**].

20

Remove 19 mm wrench tool.

21

Install top cap to outer tube at fully extended position [**00797-08 top cap tool, 10 Nm**].

22

Set main spring preload, rebound and compression adjusters [**according to chapter setup data in Mounting Instructions**].

23

Install front fork legs in vehicle at position marked in point 4, or at recommended front fork leg position [**according to chapter setup data in Mounting Instructions**].

24

Remaining installation [**instructions according to vehicle service manual**].

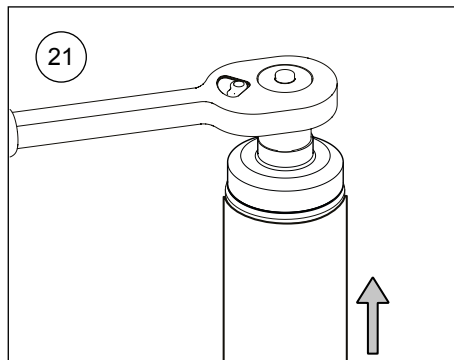

6 TECHNICAL SPECIFICATIONS

Front fork length

See specification card for your specific Front Fork Cartridge Kit.

Stroke

See specification card for your specific Front Fork Cartridge Kit.

Compression adjustment

Maximum open valve about 25 clicks.

Rebound adjustment

Maximum open valve about 25 clicks.

Main spring preload adjustment

0 - 18 mm (0 - 18 turns)

Main spring rate

See specification card or Mounting Instructions for your specific Front Fork Cartridge Kit.

Front fork fluid level

See Mounting Instructions for your specific Front Fork Cartridge Kit.

7 INSPECTION AND MAINTENANCE

Preventive maintenance and periodic inspection procedures help to keep the front fork in proper condition. For additional service, please contact an authorized Öhlins service center.

Caution!

Do not use strong detergents that can damage the front fork surfaces. Thinner and brake cleaner will dry out seals, increase the risk of friction, oil leakage and poor function.

Caution!

Use Öhlins High Performance Front Fork fluid 01309-xx.

Inspection points

1. Examine the fork leg for external oil leakage.
2. Examine the inner fork leg for scratches, dents or other defects that can damage the seal and/or bushing.
3. Examine the fender brackets and the brake calliper attachments.
4. Examine the front fork attachments to the vehicle.

Inspection intervals

Normal use: Once a year or every 5 000 km

Racing use: Every 10 hours

Service intervals

Normal use: Every third year or every 30 000 km

Racing use: Once a year or every 30 hours

Service at an authorized Öhlins service center.

Disposal

Hand over your discarded Öhlins products to an authorized Öhlins service center for proper disposal.

Your Öhlins retailer:

Öhlins Racing AB
Box 722
SE-194 27, Upplands Väsby
Sweden

Phone: +46 (0)8 590 025 00
Fax: +46 (0)8 590 025 80
www.ohlins.com



www.ohlins.com