

**Note!**

Please note that there can be small differences between your product and the images in these instructions.

**Note!**

Please note that during storage and transport, especially at high ambient temperature, some of the oil and grease used for assembly may leak and stain the packaging. This will not cause damage to the product, wipe off the excessive oil or grease with a cloth.

**Kit Contents**

Description	Part No	Pcs
Front fork kit	FGK235	1
Sticker set Öhlins		1
Owner's manual	07284-01	1

**Warning!**

This kit should only be installed by an authorized Öhlins dealer. The installation procedure requires certain tools.

**Note!**

Before you install this product, check the kit contents. If anything is missing, please contact an Öhlins dealer.

**Warning!**

Before you install this product, read the Öhlins Owner's manual and this document. This product is an important part of the vehicle and the vehicle stability.

## Front Fork Kit for Yamaha YZF-R1 YZF-R6

# FGK 235

## Mounting Instructions



# MOUNTING INSTRUCTIONS

## TOOLS, GREASE AND FLUID

### Tools needed for the original front fork

- Refer to the vehicle service manual for tools needed for removing/installing the front fork from the vehicle.
- Refer to the vehicle service manual for tools needed for removing the cartridge from the front fork.

### Grease and fluid:

Function grease	00159-02
Öhlins front fork fluid	01309-01

### Tools needed for the Öhlins cartridge

- 17 mm allen key socket with extension (adaptor)
- 19 mm wrench (shaft extension)
- 3 mm allen key (compression and rebound bleed adjusters)
- 14 mm socket (preload adjuster)
- Ruler (oil level)

Öhlins tool 01765-03 (shaft extension)

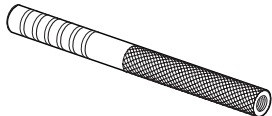

Öhlins tool 00797-08 (top cap)



Öhlins tool 01797-07 (seal head)

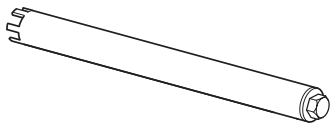

# MOUNTING INSTRUCTIONS

## 1 - Remove the original front fork

### **⚠ Warning!**

We strongly recommend to let an Öhlins dealer install this product.

### **⚠ Warning!**

If you work with a lifted vehicle, make sure that it is safely supported to prevent it from tipping over.

### **👁 Note!**

When you work with this product, see the vehicle service manual for vehicle specific procedures and important data.

### **👁 Note!**

Before you install this product clean the vehicle.

### 1.1

Put the motorcycle on a work stand so that the front wheel barely touches the ground.

### 1.2

Remove the front fender, brake calipers and the front wheel.

### 1.3

Release the spring preload.

### 1.4

Loosen the screws to loosen the upper triple clamp.

### 1.5

Loosen (do not remove) the top cap ½ turn.

### 1.6

Loosen the screws to loosen the lower triple clamp.

### 1.7

Remove the front fork legs from the triple clamps.

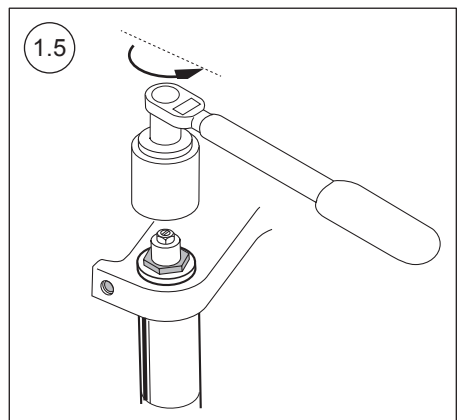
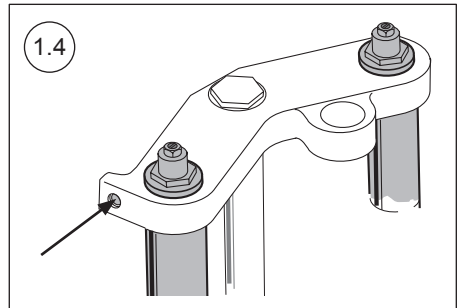
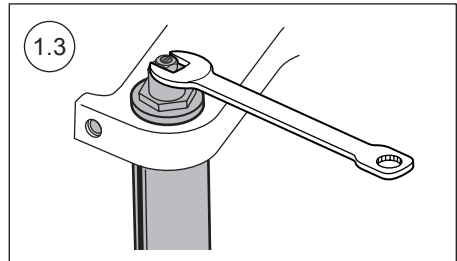
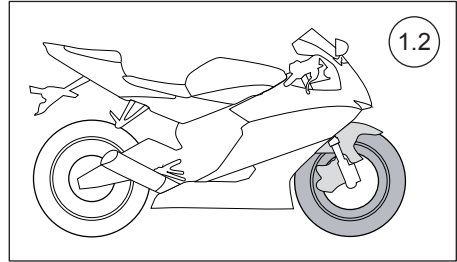

# MOUNTING INSTRUCTIONS

## **2 - Disassemble the original front fork**

### **2.1**

Loosen the top cap from the outer tube.

### **2.2**

Pull down the outer tube.

### **2.3**

Loosen and remove the top cap from the shaft, see the vehicle service manual for correct tool.

### **2.4**

Remove the spring and surrounding parts from the fork leg.

Drain the fork leg from oil.

### **2.5**

Loosen the cartridge, see the vehicle service manual for correct tool.

### **2.6**

Remove the cartridge from the fork leg.

# MOUNTING INSTRUCTIONS

## 3 - Install the Öhlins front fork kit

### ⚠ Caution!

*Do not mix the parts. Work with only one fork leg at a time.*

### ⚠ Caution!

*The front fork kit consists of one compression cartridge and one rebound cartridge.*

#### Important:

- Install the cartridge marked "Reb" (Rebound) in the right side fork leg.
- Install the cartridge marked "Comp" (Compression) in the left side fork leg.

#### 3.1

Remove the top cap.

#### 3.2

Remove the spring support and the preload tube.

#### 3.3

Remove the cylinder tube from the cartridge.

### ⚠ Caution!

*Be careful not to damage the piston ring.*

#### 3.4

Apply function grease (00159-02) on the adaptor thread. Insert the cylinder tube carefully into the fork leg. Use a 17 mm Allen key socket with extension to tighten the cylinder tube adaptor. Tighten to 40 Nm.

### ⚠ Caution!

*Be careful not to damage the inner surface of the cylinder tube when tightening with the Allen key.*

#### 3.5

Pour 0,5 litre Öhlins Front Fork fluid into the fork leg.

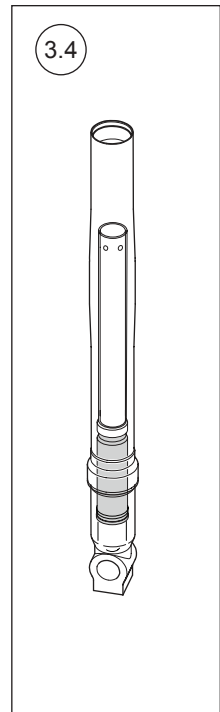
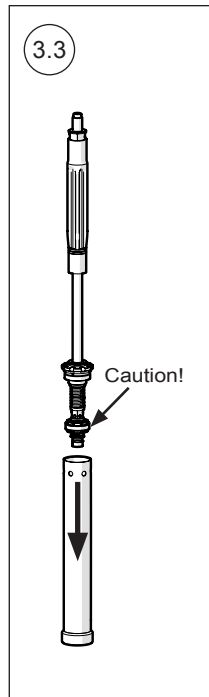
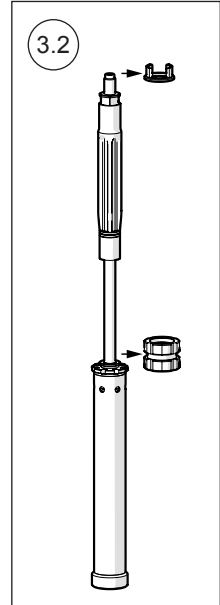
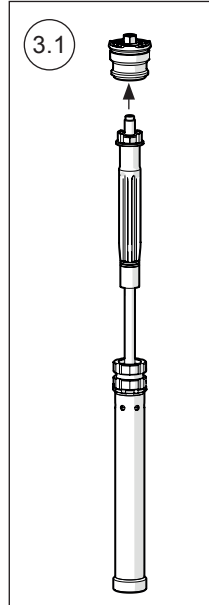

# MOUNTING INSTRUCTIONS

## ⚠ Caution!

*Make sure that the piston ring is in correct position and be careful not to damage it.*

### 3.6

Apply function grease (00159-02) on the seal head thread.

Insert the shaft assembly carefully in the fork leg. Tighten the seal head with tool (01797-07). Tighten to 20 Nm.

### 3.7

Use a 3 mm Allen key to open the compression and the rebound bleed adjusters fully. Install the top cap directly to the shaft extension (No spring or preload tube). Pull up the outer tube and tighten it to the top cap. Only tighten with your hand.

### 3.8

Pull the outer tube up and down 10-15 times to pump out all air from the cartridge.

### 3.9

Remove the top cap from the fork leg.

### 3.10

Make sure that the shaft assembly is in the bottom of the fork leg and that the outer tube is in its bottom position.

Measure the oil level with a ruler. See setup data and oil level-force diagram in this folder.

### 3.11

Attach tool (01765-03) on the top of the shaft extension. Install:

- preload tube (A)
- spring (B)
- upper spring support (C)

See the Owner's Manual for available springs.

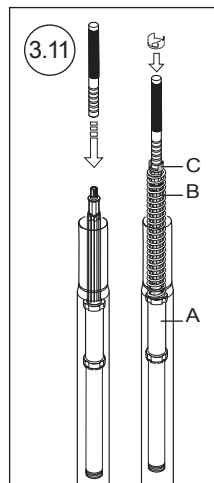
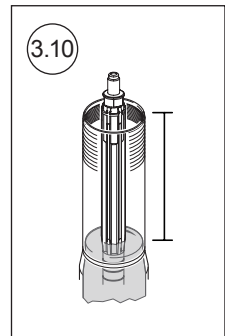
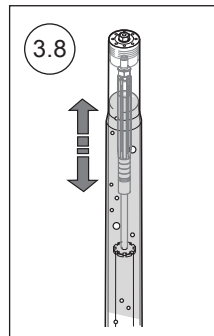
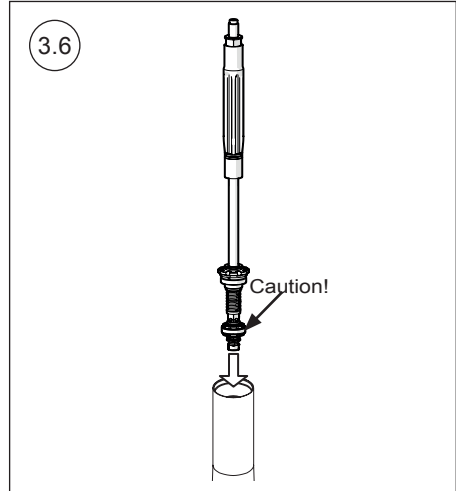

# MOUNTING INSTRUCTIONS

## 3.12

Pull up the shaft assembly and grab the spring support with a 19 mm wrench.

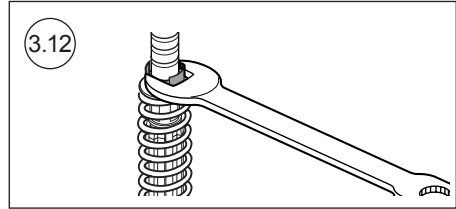

## 3.13

Make sure that the compression/rebound adjusters are fully open before installing the top cap.

Use a 3 mm Allen key to open the compression and rebound bleed adjusters.

Use a tool 14 mm socket for the preload adjuster.

Remove the pull-up tool and install the top cap to the shaft extension. Tighten to 15 Nm.

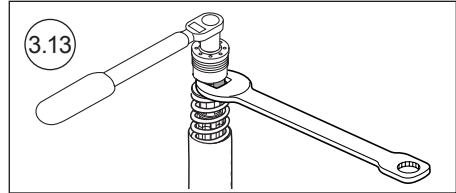

## 3.14

Pull up the outer tube. Make sure the fork leg is in a fully extended position. Use tool (00797-08) to tighten the top cap to the outer tube.

Tighten to 10 Nm.

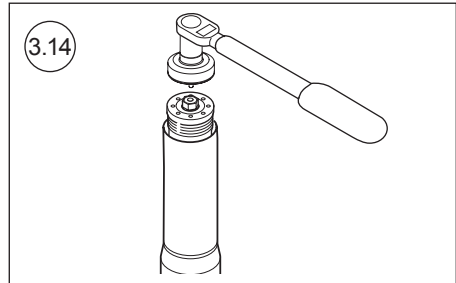

## 3.15

Set the spring preload, rebound and compression adjusters, see setup data in this manual.

Use a 3 mm Allen key for the compression and rebound bleed adjusters.

Use a tool 14 mm socket for the preload adjuster.

## 3.16

Install the front fork legs into the triple clamps at the position recommended in setup data (Fork leg position). See the vehicle service manual for correct procedure and tightening torque.

## 👁 Note!

*Measure the fork leg position from the upper triple clamp to the top of the outer tube.*

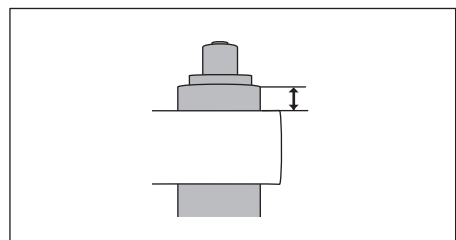

# SETUP DATA

## Recommended setup

Compression adjustment	12	clicks
Rebound adjustment	12	clicks
Suspension fluid level	160	mm
Minimum suspension fluid level	185	mm
Suspension fluid part number	01309-xx	
Front fork leg position	Standard	

# MAIN SPRING GUIDE

Make sure you choose the correct main spring for your rider weight, driving style and preferences. Below you find a general recommendation of main spring rate for your weight. Contact an authorized Öhlins service center for advice.

## Note!

Only 8790-xx main springs are packed in pairs.

Rider weight [kg]	50	60	70	80	90	100	110
Spring rate [N/mm]	9	9	9,5	10	10,5	10,5	11
Preload [mm]	7	9	8	7	7	9	8
Part number (pair)	08790-90	08790-90	08790-95	08790-10	08790-05	08790-05	08790-11
Part number (single)	04744-90	04744-90	04744-95	04744-10	04744-05	04744-05	04744-11

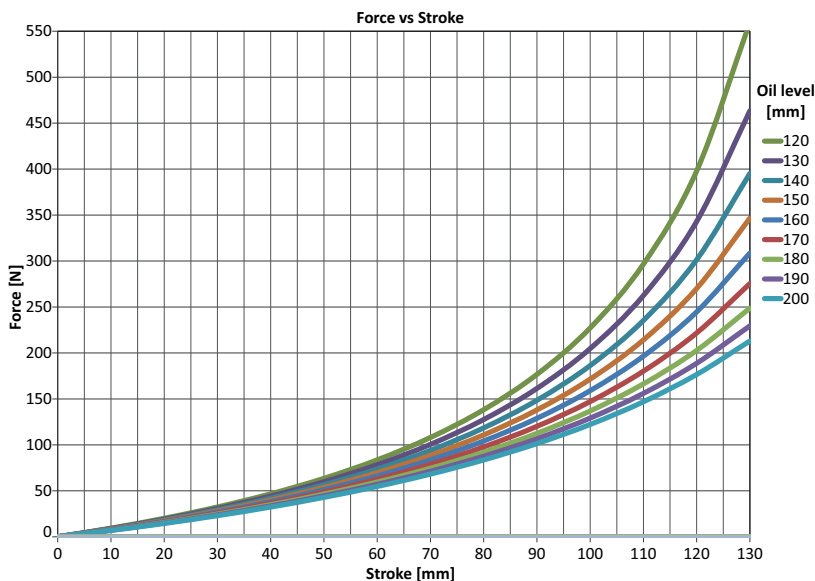

Öhlins products are subject to continuous improvement and development, therefore, although these instructions include the most up-to-date information available at the time of printing, minor updates may occur.

To find the latest information contact an Öhlins distributor. Please contact Öhlins if you have any questions regarding the contents in this document.

Part no. MI\_FGK235\_3  
Issued 2020-07-03

© Öhlins Racing AB. All rights reserved. Any reprinting or unauthorized use without the written permission of Öhlins Racing AB is prohibited.

Öhlins Racing AB  
Box 722  
S-194 27 Upplands Väsby, Sweden  
Phone +46 8 590 025 00  
fax +46 8 590 025 80



[www.ohlins.com](http://www.ohlins.com)