

Kit Contents		
Description	Part No	Pcs
Shock absorber	DU 125	1
Bracket	01082-17	1
Reservoir bracket	03102-21	1
Screw M6x14	00382-16	1
Screw M6x12	01046-36	1
Screw M6x20	05404-03	2
Tie-rod	00231-01	2
Sticker "Memo notes"	01180-01	1
Sticker set	10207-01	1
Owner's manual	07241-02	1

**Note!**

Please note that there can be small differences between your product and the images in these instructions.

**Note!**

Please note that during storage and transport, especially at high ambient temperature, some of the oil and grease used for assembly may leak and stain the packaging. This will not cause damage to the product, wipe off the excessive oil or grease with a cloth.

**Note!**

Before you install this product, check the kit contents. If anything is missing, please contact an Öhlins dealer.

**Warning!**

Before you install this product, read the Öhlins Owner's manual. This product is an important part of the vehicle and the vehicle stability.

## Shock absorber for Ducati Monster

# DU 125

## Mounting Instructions

# MOUNTING INSTRUCTIONS

## **⚠ Warning!**

*We strongly recommend to let an Öhlins dealer install this product.*

## **⚠ Warning!**

*If you work with a lifted vehicle, make sure that it is safely supported to prevent it from tipping over.*

## **👁 Note!**

*When you work with this product, see the vehicle service manual for vehicle specific procedures and important data.*

## **👁 Note!**

*Before you install this product clean the vehicle.*

**1**

Put the motorcycle on a work stand or lift it so that the rear wheel barely touches the ground.

**2**

Remove the upper right hand screw to the rear subframe.

**3**

Remove the lower and upper screw to the std shock absorber.

**4**

Remove the std shock absorber.

**5**

Mount the Öhlins unit with the hose to the right hand side pointing rearwards. Fasten the rear subframe screw.

## **👁 Note!**

*Lower the vehicle so that the suspension is slightly compressed before you tighten the screws.*

**6**

Mount the supplied bracket (01082-17) at the inside of the silencer.

**7**

Mount the reservoir bracket (03102-21) to the bracket (01082-17) using M6x12 screws (01046-36).

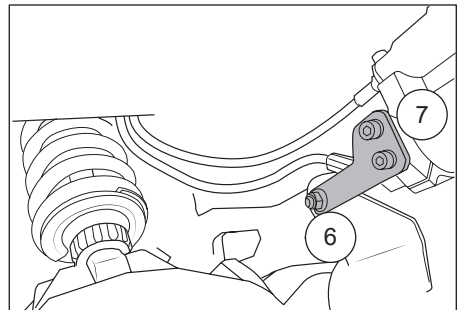
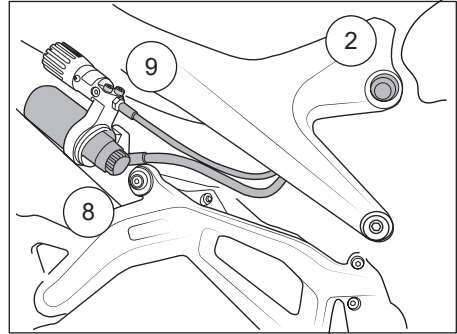

**8**

Slide the reservoir into the reservoir bracket and position it according to the picture, so the hose is not interfering with anything. Use M6x14 screw (00382-16) to clamp the reservoir.

**9**

Use M6x20 screws (05404-03) to fasten the preload adjuster to the reservoir bracket.

**10**

Use tie-raps (00231-01) to fasten the hoses.

## **👉 Caution!**

*Make sure that you tighten all screws to the correct torque and that nothing fouls or restricts movement of the shock absorber when the suspension is fully compressed or extended.*

# MOUNTING INSTRUCTIONS

This page intentionally left blank

# ADJUSTMENTS

## **⚠ Warning!**

Before you ride/drive, always make sure that the setup is according to the recommended setup data. Read about adjustments and setting up in the Öhlins Owner's Manual before you make any adjustments. Contact an Öhlins dealer if you have any questions about setting up.

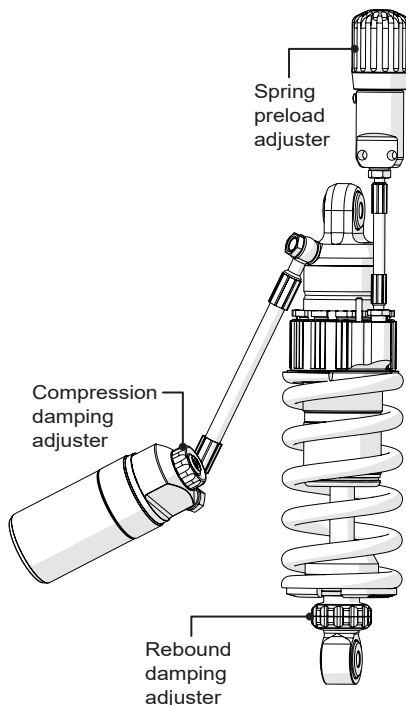

# SETUP DATA

Length	293.5	mm
Stroke	60	mm
Rebound	14	clicks
Compression	8	clicks
Spring preload	7	mm

## Recommended Free sag and Ride height

R1-R2		
R1-R3	50	mm
F1-F2		
F1-F3	47	mm

## Recommended spring

01093-31 (95 N/mm)

Spring free length, 150 mm.

Öhlins products are subject to continuous improvement and development, therefore, although these instructions include the most up-to-date information available at the time of printing, minor updates may occur.

To find the latest information contact an Öhlins distributor. Please contact Öhlins if you have any questions regarding the contents in this document.

Part no. MI\_DU125\_0  
Issued 2021-09-13

© Öhlins Racing AB. All rights reserved. Any reprinting or unauthorized use without the written permission of Öhlins Racing AB is prohibited.

Öhlins Racing AB  
Box 722  
S-194 27 Upplands Väsby, Sweden  
Phone +46 8 590 025 00  
fax +46 8 590 025 80



[www.ohlins.com](http://www.ohlins.com)